



**ROCKCOTE**  
construction systems

2024

DESIGN AND INSTALLATION GUIDE

**WALSC**<sup>®</sup>  
AAC PANEL SYSTEMS

# Intertenancy Wall System

LIGHT  
75

---

For  
Multi-Residential  
Buildings

[walsc.com.au](http://walsc.com.au)



# Contents

<b>01</b>	<b>INTRODUCTION</b>	<b>04</b>	<b>07</b>	<b>DETAILING</b>	<b>13</b>
	1.1 About Walsc			7.1 Control Joints	
	1.2 What is AAC			7.2 Fixing	
	1.3 How is AAC made			7.3 Edge Distance & min width	
	1.4 Scope			7.4 Height Limitations	
	1.5 Limitation				
	1.6 National Construction Code				
<b>02</b>	<b>BENEFITS</b>	<b>06</b>	<b>08</b>	<b>INSTALLATION</b>	<b>14</b>
				8.1 Installation guide	
				8.2 Plumbing & Electrical services	
<b>03</b>	<b>MATERIAL PROPERTIES</b>	<b>07</b>	<b>09</b>	<b>DELIVERY, STORAGE &amp; HANDLING</b>	<b>15</b>
<b>04</b>	<b>SYSTEM OVERVIEW</b>	<b>08</b>		9.1 Delivery	
<b>05</b>	<b>SYSTEM PERFORMANCE</b>	<b>10</b>		9.2 Storage & Handling	
	5.1 Structural			9.3 Good lifting techniques	
	5.2 Fire resistance		<b>10</b>	<b>HEALTH &amp; SAFETY</b>	<b>16</b>
	5.3 Fire Hazard		<b>11</b>	<b>CONSTRUCTION DETAILS</b>	<b>17</b>
	5.4 Acoustic Performance				
<b>06</b>	<b>SYSTEM COMPONENTS</b>	<b>12</b>			

Front cover image courtesy of the Property Owners

## Warranty

Walsc guarantees its AAC products to be free of defect in material and manufacture. Walsc AAC Panel Systems are customised to gain the most satisfaction and guaranteed to offer excellent performance when installed and maintained in line with the latest Design and Installation Guide. Minimum of 15 Years warranty of reinforced Walsc AAC Panel within Walsc AAC Panel Systems from date of purchase are provided to our clients. Further information please call us or visit [www.walsc.com.au](http://www.walsc.com.au)

Walsc is a registered trademark of Sipo Building Solutions Pty Ltd. ABN: 46 614 424 225  
Walsc is a registered trademark of Nanjing Asahi New Building Materials Co., Ltd.

# The Reinforced Walsc AAC Panel is the soul of all our Walsc AAC Panel Systems.



The design versatility and flexibility of the panel and systems provide a better wall and flooring solution for home owners, developers, architects and all building consultants. Building a high quality energy efficient dream home is no longer a dream of the minority.





# 1 Introduction

## 1.1 About Walsc

Walsc AAC Panel Systems (Walsc) provide world leading innovative, top quality autoclaved aerated concrete, AAC products to the market. Our AAC panel systems provide high quality, superior performance and cost-effective solutions for wall applications for house and low-rise residential buildings, and also for high-rise commercial and residential buildings. Our AAC panel systems are tested and assessed for compliance with the requirements of the building codes of Australia and provide confidence and certainty to regulatory authorities and the market. The systems have been accredited CodeMark Certification via CertMark in Australia. Walsc was established in 2014 and has become one of the Australia's leading Autoclaved Aerated Concrete (AAC) suppliers. Over the past few years, Walsc has participated in hundreds of projects ranging from low-rise residences, aged care facilities, warehouses to high-rise apartments and commercial buildings. Now Walsc is widely recommended by architects, certifiers and builders because of its premium quality, comprehensive wall and flooring solutions, and strong technical support.

At Walsc, we provide better wall and flooring solutions for your project!

## 1.2 What is AAC?

Autoclaved aerated concrete is manufactured from water, cement, lime, silica sand and a small amount of aluminium powder as expanding agent. The produce techniques impart many unique properties to AAC, making it both economically and environmentally friendly better than other masonry building materials. It can be customised in blocks, wall, floor and roof panels with a range of sizes depending on specific applications, allowing for maximum efficiency and flexibility in construction.

## 1.3 How is AAC Made?

The raw materials are mixed into slurry state and poured into a mould (a very large cake tin). The expanding agent (aluminium powder) instantly initiates a chemical reaction to create numerous tiny and finely-dispersed hydrogen air bubbles. Meanwhile, it causes the mixture to expand to almost twice its original volume. Once the mixture turning is hard enough (semi-solid) to be wire cut into required panel sizes in a heated room, it will be transported into the cutting machine. Then the sliced semi-solid material will be cured with high-pressure steam in autoclaves for up to 12 hours. During this curing

process, the hydration of the concrete is accelerated by the high pressure steam.

The combination of the expanding chemical reaction and autoclave curing process gives AAC its unique properties that are beneficial to buildings.

## 1.5 Scope

This guide is intended for use by qualified and experienced architects, engineers and builders for the design, specification and construction of inter-tenancy walls of multi-residential buildings. Multi-residential buildings are assumed to be those within the scope of Class 1 & 10 buildings as defined in the National Construction Code - Building Code of Australia and include the following:

- Single dwellings (detached house).
- Attached dwelling separated by a fire resisting wall e.g. Town houses, villa units etc.
- Non-habitable buildings e.g. private garages, sheds etc.

\*Any variation of the system outlined in this guide is considered outside the scope and must be evaluated by the relevant professional consultant.





This guide has been prepared by Walsc to provide design, installation and technical information for builders, building consultants, engineers and architects. The information related specifically to Walsc AAC products and must not be used in relation to other AAC manufacturers. The guide does not replace the need for qualified designers (e.g. engineers & architects) to specify project specific information and it is their responsibility to confirm the suitability of using Walsc AAC products for a particular project. Walsc accepts no liability for errors or omissions in this guide and the user must check with Walsc to ensure the current edition of this guide is being used.

### 1.7 National Construction Code (NCC)

The National Construction Code sets out the requirements for building construction work in Australia. It consists of Volume I (commercial and large residential buildings) and Volume II (low-rise residential buildings). As defined in the scope, this guide relates to the inter-tenancy walls (commonly known as party walls) for low-rise residential buildings classified as Class 1 & 10 of the NCC 2019 Volume II Amendment 1. The performance requirements of NCC that related to party walls for low-rise residential buildings are as follows:

**Table 1.** *Relevant NCC Volume II Amendment 1 Clauses*

Relevant NCC Volume II Amendment 1 Clauses	System Compliance
3.7.3.2(a)(i)(A) Fire protection of separating Walls	√
3.7.1.1 Non-combustible materials	√
3.8.6.3 Determination of airborne and impact sound insulation ratings for walls	√
3.8.6.2 Sound insulation rating of walls	√

The system performance section of this guide outlines the performance of the Walsc Inter-tenancy Wall System with respect to the above NCC requirements.

# 2 Benefits



### Fire resistance

AAC material has earned a reputation for its outstanding fire-resistant properties. It is non-combustible and offers the best fire-resistant performance among any building material currently on the market. In case of fire, it does not release toxic gases and smokes or drip burning materials and prevents spreading of fire.



### Acoustic insulation

Reinforced Walsc AAC Panel is proven to be an extraordinary acoustic insulation material by building a defence against external noise pollution. Its sound insulation value is greater than other materials of the same weight.



### Thermal insulation

The low thermal conductivity along with thermal mass gives the reinforced Walsc AAC Panel high R-values. These thermal efficiencies reduce energy costs by eliminating the original reliance on cooling and heating appliances.



### Compliance Assured

The wall systems have been accredited CodeMark Certification and all systems are undergoing continuous testing by NATA accredited laboratory to ensure its compliance with various requirements especially in fire resistance and acoustic insulation.



### Strong & Durable

Reinforced Walsc AAC Panel enhances the strength and security by combining with the corrosion protected steel, the durability is quite similar to concrete.



### Eco-friendly

All the ingredients contained in the reinforced Walsc AAC Panel are natural and toxic-free which also means no pollutant and toxic gases will be generated during the manufacture and installation. Even the scrap material that is produced during the utilisation can be recycled.



### Fast Construction

Panelised Walsc AAC products with flat packed delivery remarkably contribute to the speed of construction. It enables laborers to install much more square footage of AAC than that of traditional masonry materials within the same period of time, promoting the efficiency during the entire lifetime of the project.

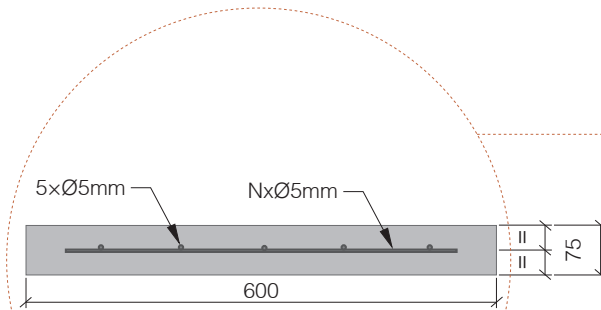


### Technical Support

We offer sales services, technical advice and support to meet the satisfaction. We actively cooperate with our customers to ensure the project is completed smoothly.

# 3 Material Properties

Reinforced Walsc AAC Panel 75mm Light is supplied with a single layer of reinforced mesh located centrally in the panel thickness.



**Fig 1. Panel Details**

Note: "N" varies with different panel sizes.

The table below outlines the material properties of reinforced Walsc AAC Panel 75mm Light.

**Table 2. Material Properties**

Property			Value
Panel Thickness	$d$	(mm)	75
Panel Width	$w$	(mm)	600
Panel Length	$L$	(mm)	up to 3300
Panel Edge Profile			Square Edge
Dry Density	$\lambda_{dry}$	(kg/m <sup>3</sup> )	450
Density for Design	$\lambda_{design}$	(kg/m <sup>3</sup> )	525
Panel Weight per SQM			(kg/m <sup>3</sup> ) 42
Reinforcement Tensile Yield Stress	$f_{yk}$	(MPa)	500
Reinforcement Characteristic Weld Strength	$V_{uk}$	(kN)	3.1
Ultimate Strength Bending Capacity	$\phi M_k$	(kNm/m)	1.0
Thermal Resistance	$R$ -Value		0.584

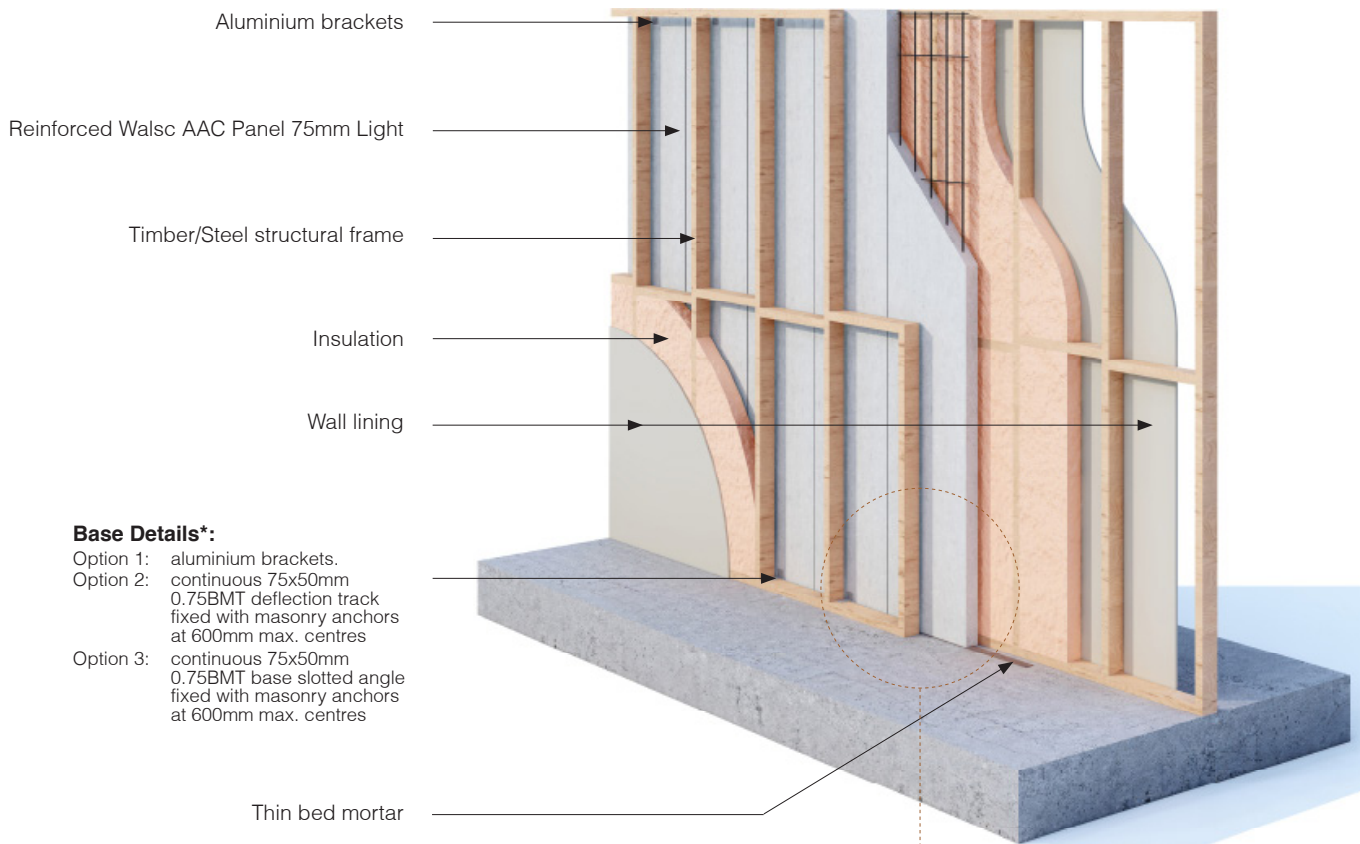
**Note:**

- Panel weight is calculated with 20% of moisture content, moisture content may varies from 6% to 30%.
- Material are tested in accordance with AS5146.



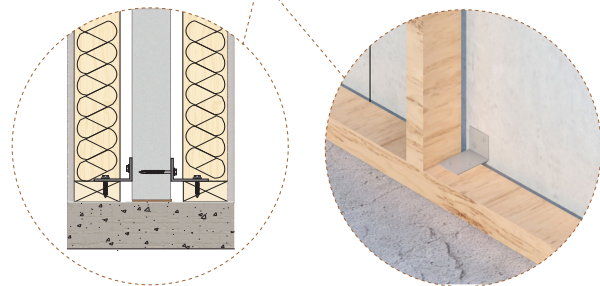
# 4 System Overview

Discontinuous Construction



**Fig 2. Discontinuous Construction System Overview**

The Walsc Inter-tenancy Discontinuous Wall System consists of reinforced Walsc AAC Panel 75mm Light installed vertically and fixed to the structural frame on each side using aluminium brackets as shown. Walsc AAC Adhesive is applied to the vertical edges where there is an adjoining panel.



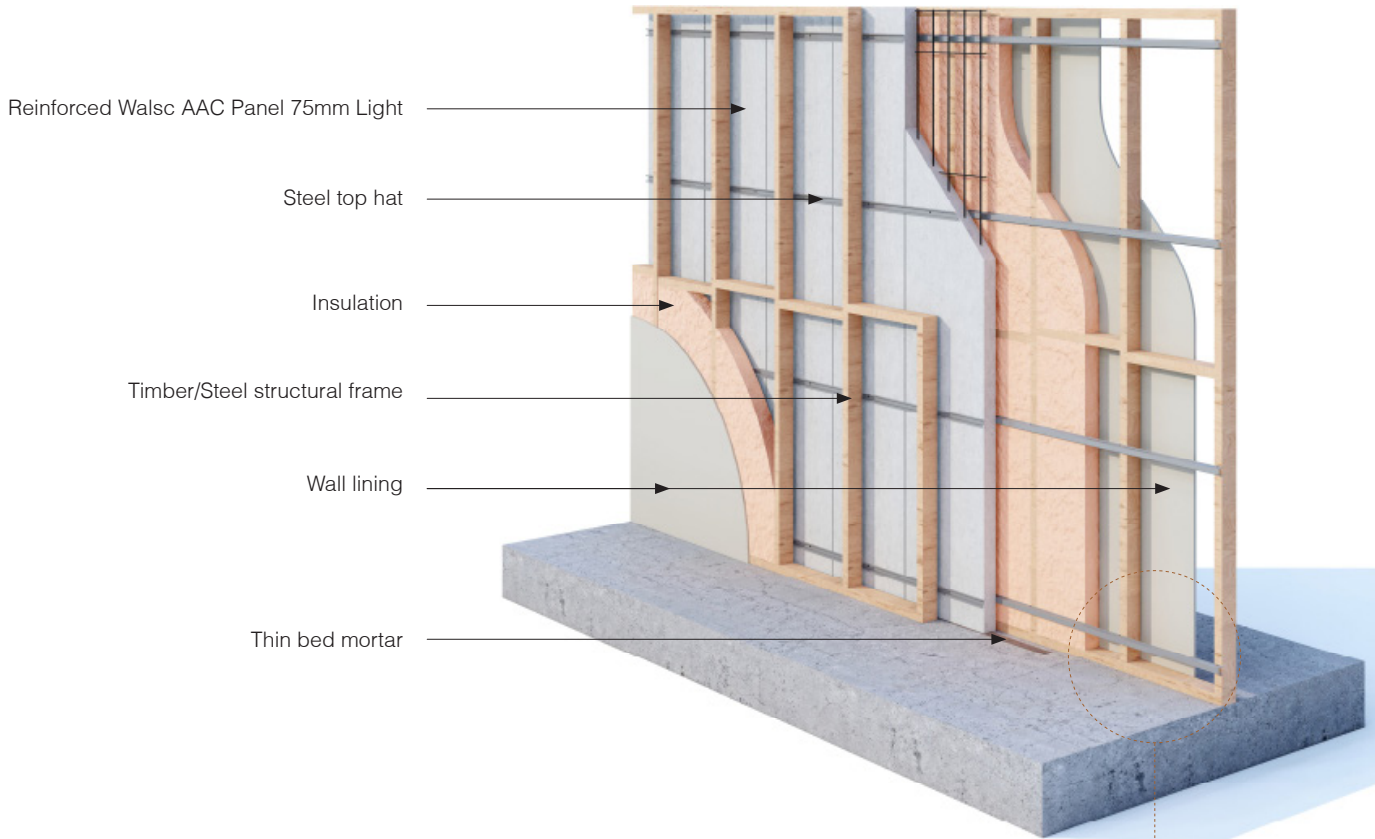
**Table 3. Discontinuous Construction**

Ref No.	Wall Lining A	Stud Depth	Cavity Insulation	AAC Panel	Stud Depth	Cavity Insulation	Wall Lining B	Wall THK.	Acoustics R <sub>w</sub> /R <sub>w</sub> +Ctr	FRL
WIW 7501	13mm Standard Plasterboard	70mm	75mm Glasswool 11kg	75mm Light	70mm	75mm Glasswool 11kg	13mm Standard Plasterboard	281mm 20mm min. Cavity	62/50	90/90/90
WIW 7502	13mm Standard Plasterboard	90mm	75mm Glasswool 11kg	75mm Light	90mm	75mm Glasswool 11kg	13mm Standard Plasterboard	321mm 20mm min. Cavity	63/52	90/90/90

**Note:**

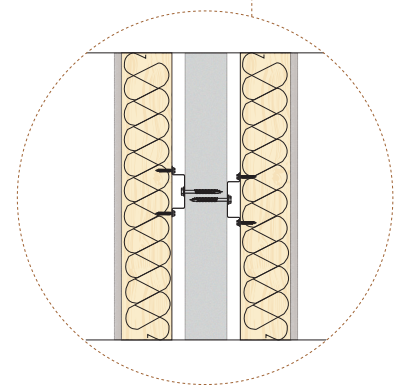
- (1). Please Check with Walsc distributor for panel availability. Distributor contact details are available at [www.walsc.com.au](http://www.walsc.com.au).
- (2). Timber frame should be built to AS1684 or AS1720.1. Steel frame should be built to AS3623 or AS4600.

Continuous Construction



**Fig 3. Continuous Construction System Overview**

The Walsc Inter-tenancy Continuous Wall System offers a steel top hat connection where the reinforced Walsc AAC Panel 75mm Light is secured to the structural frame with horizontal steel top hats as shown. Walsc AAC Adhesive is applied to the vertical edges where there is an adjoining panel.



**Table 4. Continuous Construction**

Ref No.	Wall Lining A	Stud Depth	Cavity Insulation	AAC Panel	Stud Depth	Cavity Insulation	Wall Lining B	Wall THK.	Acoustics R <sub>w</sub> /R <sub>w</sub> +C <sub>tr</sub>	FRL
WIW 7503	13mm Plasterboard (10.4kg/m <sup>2</sup> )	70mm	90mm Glasswool 14kg	75mm Light	70mm	90mm Glasswool 14kg	13mm Plasterboard (10.4kg/m <sup>2</sup> )	289mm 24mm min. Cavity	61/50	90/90/90
WIW 7504	13mm Plasterboard (10.4kg/m <sup>2</sup> )	90mm	90mm Glasswool 11kg	75mm Light	90mm	90mm Glasswool 11kg	13mm Plasterboard (10.4kg/m <sup>2</sup> )	329mm 24mm min. Cavity	61/51	90/90/90

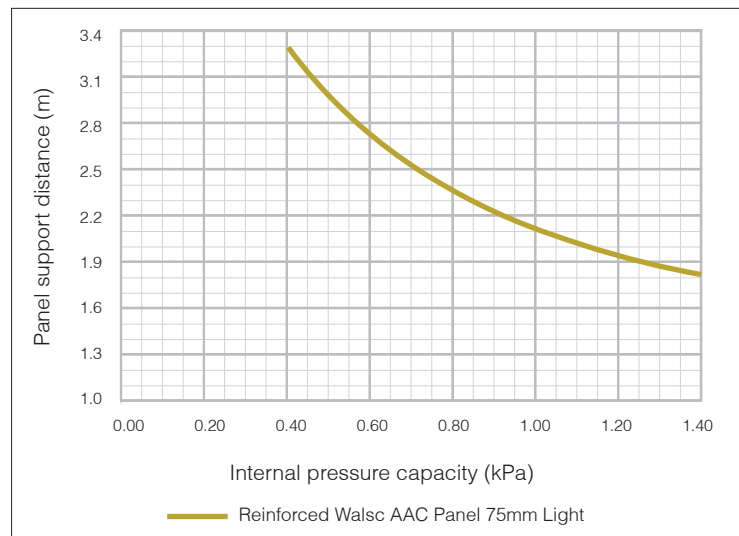
**Note:**

- (1). Please Check with Walsc distributor for panel availability. Distributor contact details are available at [www.walsc.com.au](http://www.walsc.com.au).
- (2). Timber frame should be built to AS1684 or AS1720.1. Steel frame should be built to AS3623 or AS4600.

# 5 System Performance

## 5.1 Structural

The reinforced Walsc AAC Panels are non-loadbearing, therefore do not support vertical loads apart from the self-weight of the panel (refer to material properties for panel density). Similarly, the panels should not be relied upon to support in-plane racking forces. The structural frame that the panels are fixed to, which can be either timber or steel, is the structural component of the wall system and must be constructed in accordance with the relevant standard (AS1684 series for timber and AS4600 or NASH Standard for steel). However, the panels will be subject to out-of-plane loading due to internal pressures. The chart below outlines the maximum internal pressure the panels can withstand. It is the responsibility of the building designer to confirm the suitability of the Walsc Inter-tenancy Wall Systems based on the design internal pressures of the building.



**Fig 4. Internal Pressure Capacity (kPa)**

The designer must ensure that the self-weight of the reinforced Walsc AAC Panels is allowed for when undertaking design of the support structure. Refer to the density for design in the Material Properties section of this Design and Installation Guide.

The fixing of the reinforced Walsc AAC Panels to the structural frame shall be in accordance with the Construction Details section. Any fixing should not be located closer than 40mm from the edge of the AAC panel, refer to section 7.2.



## 5.2 Fire Resistance

In the event of a fire, an inter-tenancy wall is required to resist the fire from spreading from one dwelling to another for a specified period of time as stated in the NCC. The main fire resisting component of the Walsc Inter-tenancy Wall System is the AAC panel situated in the cavity between the two structural frames. The assumed sequence of events during a fire on either side of a inter-tenancy wall are as follows:

1. Fire erupts on one side of the inter-tenancy wall.
2. The fixings on the fire side of the AAC panel are weakened and lose connection to the panel.
3. The structural frame and plasterboard on the fire side falls away from the reinforced Walsc AAC Panel.  
The AAC panel protects the fixings and structural frame on the non-fire side for a specified period.
4. The AAC panel & plasterboard on the non-fire side protect the occupants on the non-fire side of the inter-tenancy wall with
5. sufficient time to allow escape for a specified period.

Reinforced Walsc AAC Panels have been tested and the load bearing inter-tenancy wall systems detailed in this Design and Installation Guide has been assessed by CSIRO to achieve an FRL of 90/90/90, refer to report FCO-3092B.

## 5.3 Acoustic Performance



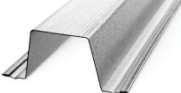





The NCC requires inter-tenancy wall to be insulated to a certain degree from sound transmission which can be either airborne or impact generated. These requirements are found in clause 3.8.6.2 of the NCC Volume 2 and consist of the wall:

- a. achieving a weighted sound reduction index with spectrum adaption term ( $R_w + C_{tr}$ ) of 50 or more;
- b. being of discontinuous construction where it separates a habitable room from a wet area room (bathroom, sanitary compartment, laundry or kitchen); and
- c. continuing to the underside of the roof above or to a ceiling that provides the same sound insulation.

Sound transmission testing has been undertaken on reinforced Walsc AAC Panels and the inter-tenancy wall systems detailed in this guide have been assessed by PKA Acoustic Consulting to achieve a  $R_w + C_{tr}$  of 50. The test and assessment reports are available at request.

# 6 System Components

**Table 5.** System Components

Product	Description	
Reinforced Walsc AAC Panel	75mm thickness in various lengths. Please contact supplier for more details.	
Aluminium Bracket	75x40x50mm with minimum thickness 1.6mm Grade 5005 Aluminium. For discontinuous construction.	
Steel Top Hat	24x30mm 0.42BMT (G550 grade) steel top hat. For continuous construction.	
Steel Top Hat to Structural Frame	Steel top hat is to be inserted into a steel clip which is screw fixed to the stud. Use Rondo 311D clip with steel top hat.	
AAC Panel to Aluminium Bracket/Steel Top Hat Screw	14-10 type 17 hex head screw, length varies with different systems. Class III corrosion resistance (minimum) as per AS3566.2-2002.	
Aluminium Bracket/Steel Top Hat to Timber Frame Screw	12-11x35mm type 17 hex head screw, class III corrosion resistance (minimum) as per AS3566.2-2002.	
Aluminium Bracket/Steel Top Hat to Steel Frame Screw	10-16x16mm tek screw, class III corrosion resistance (minimum) as per AS3566.2-2002.	
Walsc AAC Adhesive	Cement based adhesive is applied to all adjoining panel edges and can also be used to patch up minor damaged areas.	
Corrosion Protection Paint	When panels are cut, the exposed ends of the reinforcement must be treated with anti-corrosion protection paint.	
Mineral Fibre	For horizontal control joints at each inter-storey junction, between top of AAC panels and roof covering and at the junction of inter-tenancy wall to external wall.	
Fire Rated Sealant	Fire rated sealant must be used in all control joints throughout the fire rated wall. Bostik Fireban One should be used .	

# 7 Detailing

## 7.1 Control Joints

Control joints must be installed through the Walsc Inter-tenancy Wall System to minimise the risk of damage occurring to the panels or render coating due to expected movement of the residential structure. Movement in residential structures can occur due to various causes including:

- Movement of the foundation material.
- Thermal shrinkage/expansion of the building materials.
- Long term shrinkage of the timber.
- Long term deflection of suspended members.

**Vertical control joints** should be located:

- a. At changes in wall heights; and
- b. At changes in wall thickness or material types; and
- c. At locations of joints in supporting structures e.g. concrete slabs; and
- d. At the following maximum spacing for sections of walls without openings.

**Table 6.** Vertical Control Joint Spacing for Walls without Openings

AS2870-2011 Site Class	Maximum horizontal spacing of vertical control joint
A or S	6.0 m
M or M-D	5.5 m
H1 or H1-D	5.0 m
H2 or H2-D	4.5 m

**Horizontal control joints** should be located at the level of the floor structure zone. That is, below the finish floor level and above the ceiling level (or above the underside of the suspend floor structure for sub-floor areas). This applies to every floor level for all wall systems.

## 7.2 Edge Distances & Minimum Width

The minimum edge distance for fixing reinforced Walsc AAC Panel shall be 40mm.

The minimum panel width shall be 200mm and containing a minimum 2 longitudinal steel bars.



# 8 Installation

## 8.1 Installation Guide

(Discontinuous Construction)

### *Prior to any construction*

1. Ensure that the stud spacing will meet the requirements for the required FRL and acoustic rating of the inter-tenancy walls in accordance with the relevant sections in this Design and Installation Guide.

### *Preparing for panel installation*

2. Ensure the stud frame has been completed and is ready for installation of the panels. This includes checking that the frame is plumb and straight, with special attention to corners of framing. At this point, only one of the wall frames should be in place to allow for easy installation of the panels.
3. Plan the panel installation, starting from one end allow for control joints as per the Construction Details section of this guide or as specified by the design engineer.
4. Install the damp proof course in accordance with the manufacturer's instructions.

### *Installing the first panel*

5. Starting from a location as chosen in the planning stage, place a thin bed mortar on the damp proof course to form a level base for the AAC panels. Work no more than 3 panel lengths (1800 for full panels) ahead of the current panel.
6. Cut the panel to the required height if necessary, to match floor joists or roofing levels. For any reinforcement that has been exposed, apply a suitable protective treatment as listed in the System Components section.
7. Place the first panel into position at the centre of the finished wall location, providing a minimum of 20mm cavity space. Temporary spacers may be used provided that they are removed prior to the completion of the wall. Ensure that the panel is level and plumb, then screw fix the aluminium brackets to the panel and stud frame. The screw fixing of each panel is to be in accordance with the Construction Details section of this guide. Each screw should be screwed in until the screw head is flush with the bracket surface. Care should be taken so as to not over tighten.

### *Installing subsequent panels*

8. Cut the next panel to the height required for floor joists or roofing. The panel at the end of the inter-tenancy walls may also need to be cut to length. For any reinforcement that has been exposed, apply a suitable protective treatment as listed in the System Components section.
9. Prepare the panel adhesive in accordance with the manufacturer's specifications. Do not use adhesive that has passed its use by date.
10. Apply panel adhesive, approximately 2mm thick, along the full edge to be joined. Ensure coverage to both the top and bottom edges of the panel. Where the panel joint is a control joint, instead leave the edges of the AAC panel clean and create a 10mm nominal gap.
11. Lift the next panel into position at the finished wall centre, and then slide it hard against the adhesive coated edge. Temporary spacers may be used provided that they are removed prior to the completion of the wall. Ensure the new panel is level and plumb. Ensure adhesive is fully coating the joining edges of the panels, then remove excess adhesive that has been squeezed out of the joint. Screw fix the brackets to the panel and stud frame in accordance with the Construction Details section of this guide, ensuring the panel remains level and plumb.
12. Repeat the above steps for all further panels.

### *Wall finishing*

13. Install the remaining side of the stud frame, and install brackets to the panel and stud frame in accordance with the Construction Details section of this guide.
14. Install the insulation if required and the selected wall lining as per the project specifications. Ensure that the fire resistant mineral fibre is installed at the top and ends of the wall.

## 8.2 Plumbing & Electrical Services

Any penetration or chasing in the wall shall only be undertaken under the strict guidance of the relevant fire engineering consultant, as it is likely to reduce the fire resistance level.

# 8 Delivery, Storage & Handling

## 9.1 Delivery

Before delivery of reinforced Walsc AAC Panels on site, an appropriate unloading area should be designated. The unloading area should be:

- Capable of supporting the weight of the reinforced Walsc AAC Panel packs. Consult the project's structural engineer if required.
- On level support and elevated off any surface that may have water run across it (e.g. outside ground, interiors without roofing).
- Kept dry either by storing inside or protected from the rain (e.g. by use of plastic wrapping).
- Large enough to contain all panels for the construction stage without stacking packs on top of each other.
- As close as possible to the installation area, to minimise the additional lifting required. This may mean designating additional unloading areas depending on the project size.

## 9.2 Storage & Handling

Wherever possible, reinforced Walsc AAC Panels should have the faces, corners and edges protected from damage. Whenever moving panels, the following precautions should be taken:

- Before lifting packs, ensure that the panels are securely strapped.
- Personnel operating lifting machinery (e.g. forklifts, cranes, trolleys) must use the appropriate techniques and equipment.
- When opening packs, appropriate measures should be taken to prevent panels from falling.
- Any opened packs are protected from the weather and secured while not in use.
- All workers have appropriate personal protection equipment (PPE) for the worksite conditions. Recommended PPE includes but is not limited to:
  - Hearing & eye protection

- Safety clothing (e.g. safety boots, well-fitting clothing)
- Respiratory protective equipment
- Sun protection (e.g. hats, long sleeves, trousers, sunscreen).

- All workers are trained in an appropriate manner for the tasks undertaken. For example, proper equipment maintenance and usage, material safety and good lifting techniques would fall into this category.
- The sequence of installation should be planned to minimise panel movements and ensure installers will have appropriate room to lift the panels.
- Whenever manually lifting single panels, a minimum of two people should carry each panel and the panel should be carried on its side (not flat). Good lifting techniques (detailed below) and a clean worksite should be maintained to minimise injuries.

## 9.3 Good Lifting Techniques

There is no proven 'best' way of lifting, as it will vary with the weight and shape of the object being lifted. The better options available are a 'deep squat' and 'semi squat' lift. The deep squat is done by bending the knees and hip to their maximums, while keeping the upper body approximately vertical. The semi squat is done by leaning the upper body forwards as a whole (while keeping the spine straight) and bending the legs to a lesser degree than the deep squat. The basic principles of good lifting are to:

- Minimise the distance between the load and the body
- Bend the knees, allowing for use of the leg muscles
- Keep the back as Straight as possible

**For more details refer to the relevant state-based safety regulation documentation (e.g. Safe Work Australia).**

# 10 Health & Safety

Reinforced Walsc AAC Panels, like all concrete members, contain crystalline silica (also known as silica dust). Prolonged exposure via inhalation can cause silicosis in the long term, among other possible conditions. As such, proper PPE usage during construction is necessary to create a safe work environment.

While AAC panels are left undamaged and intact, there is no potential health risk. As such, touching the material with bare skin is not an immediate problem. Protection may be suitable however, to prevent abrasion from skin contact. However, when the material has been broken down by any process such as cutting, drilling, chasing or sanding silica dust is generated. As such, this generates an increased risk of health problems. Long term exposure increases this risk, so it is advised that precautionary measures are taken.

Either protective masks or dust extraction are recommended for usage as a preventative measure during any process that breaks down the panels. Wet cutting of the panels is not

recommended. Protective respirators should be of Class P1 or P2 (to AS/NZS1715 and AS/NZS1716) and recommended for dust, at a minimum. Dust extraction systems should be appropriately filtered as required by local council regulations. The site should also be cleaned at regular intervals (e.g. daily) to prevent dust accumulation.

Other preventative measures not related to the inhalation of silica dust may include:

- Eye protection in accordance with AS1336
- Protective footwear in accordance with AS2210
- Ear plugs/earmuffs to an appropriate rating for the tools being used, in accordance with AS1270
- Protective clothing such as long sleeve shirts and trousers, or overalls to prevent possible skin irritation.
- This will also have the added benefit of protecting outside workers from the sun.

**For further details, see the MSDS at [www.walsc.com.au](http://www.walsc.com.au).**



**SAFETY ALWAYS COMES FIRST, WEAR PPE!**



# 11 Construction Details

Figure	Construction Details Overview	Page
<i>11.1 Discontinuous System</i>		
5	System Cross Section Detail	18
6	Panel Orientation Elevation Detail	19
7	Fixing Location Detail	20
8	Base of Wall Detail - Option 1	20
9	Base of Wall Detail - Option 2	21
10	Base of Wall Detail - Option 3	21
11	Roof parapet Detail	22
12	External Wall Junction Detail 1	22
13	External Wall Junction Detail 2	23
14	Vertical Control Joint Detail	23
15	Corner Vertical Control Detail	24
16	Inter-storey Junction Detail	24
<i>11.2 Continuous System</i>		
17	System Cross Section Detail	25
18	Panel Orientation Elevation Detail	26
19	Panel to Frame Connection Detail - Option 1	27
20	Panel to Frame Connection Detail - Option 2	27
21	External Wall Junction Detail 1	28
22	External Wall Junction Detail 2	29
23	Vertical Control Joint Detail	29
24	Corner Vertical Control Joint Detail	30

11.1 Discontinuous System

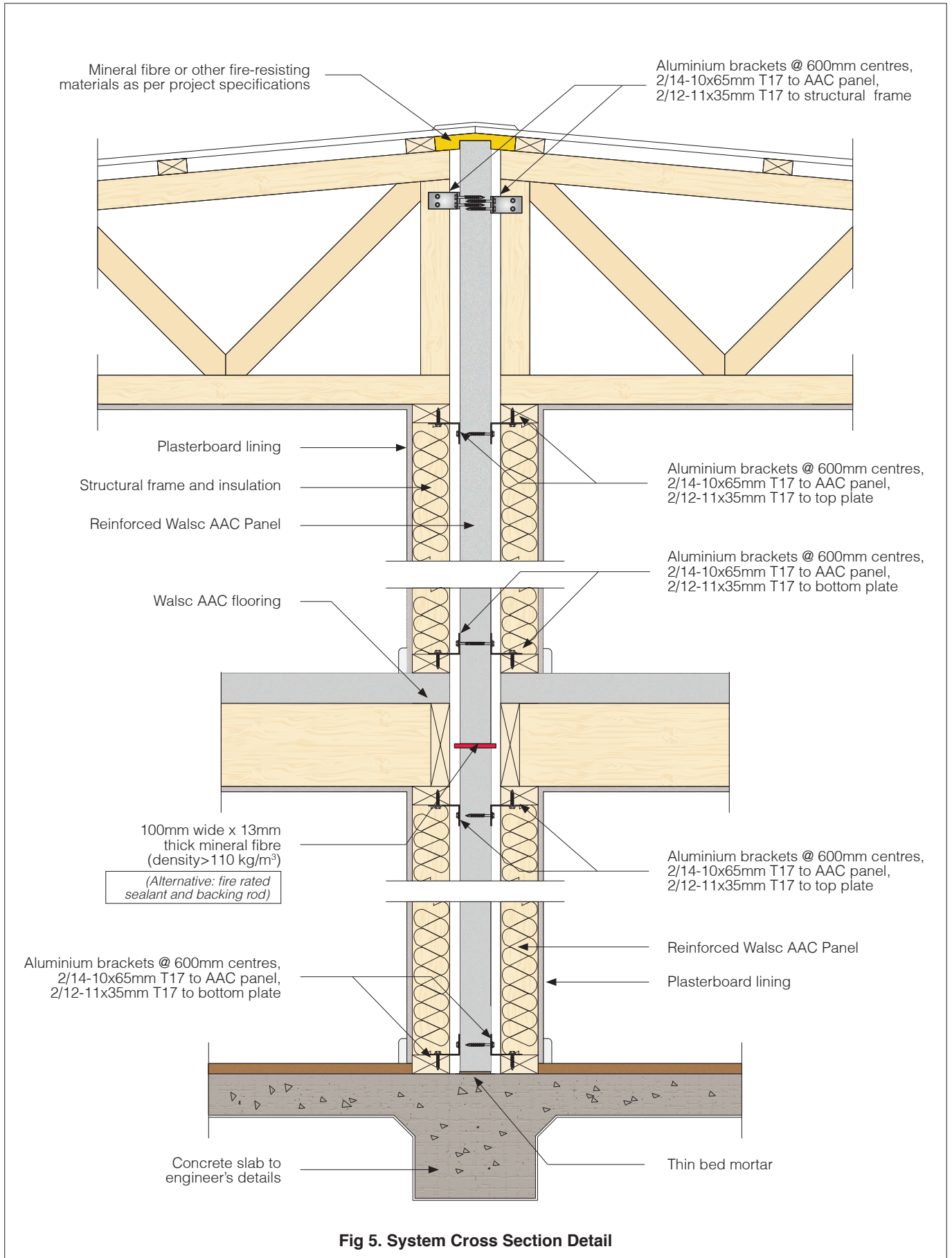


Fig 5. System Cross Section Detail

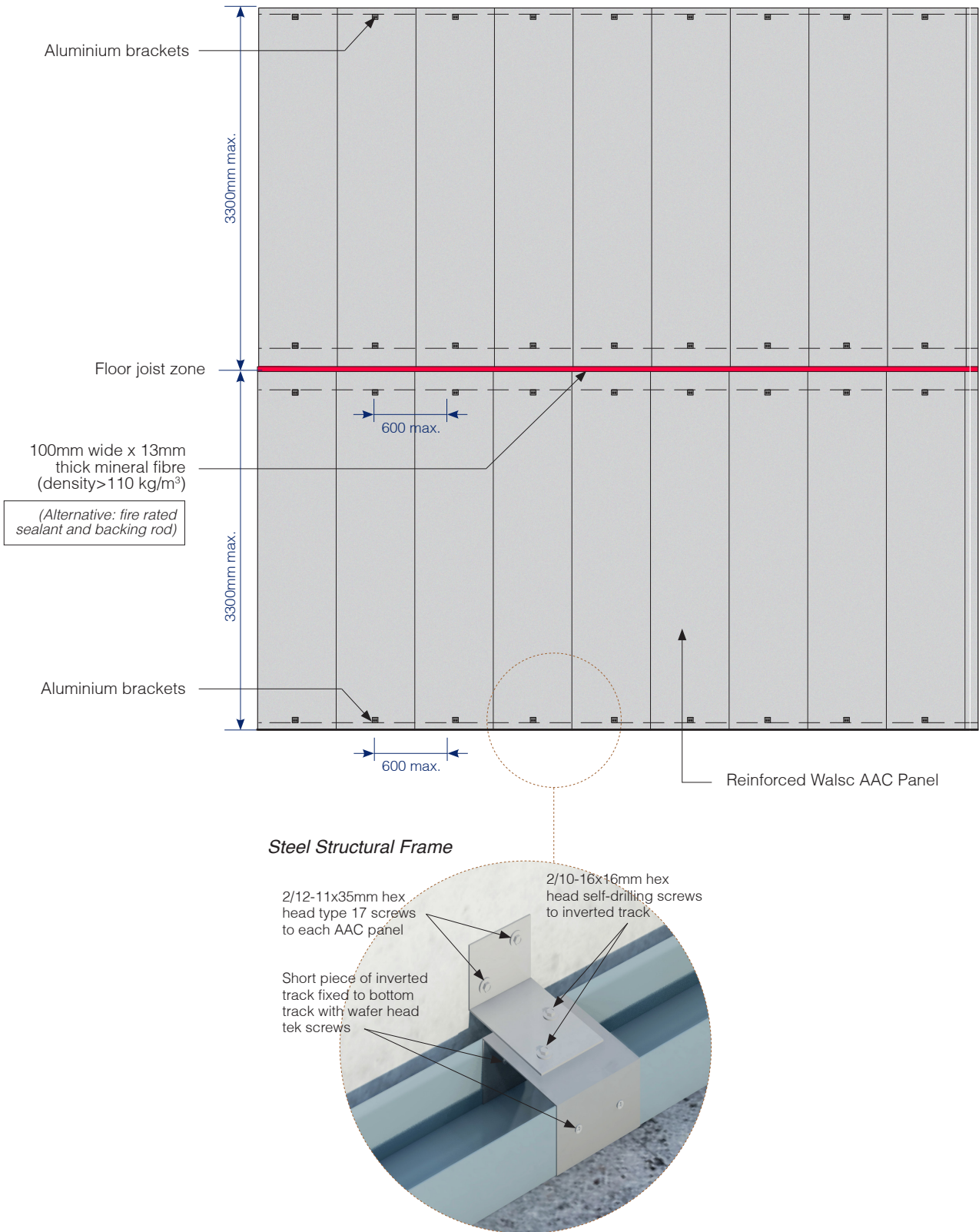
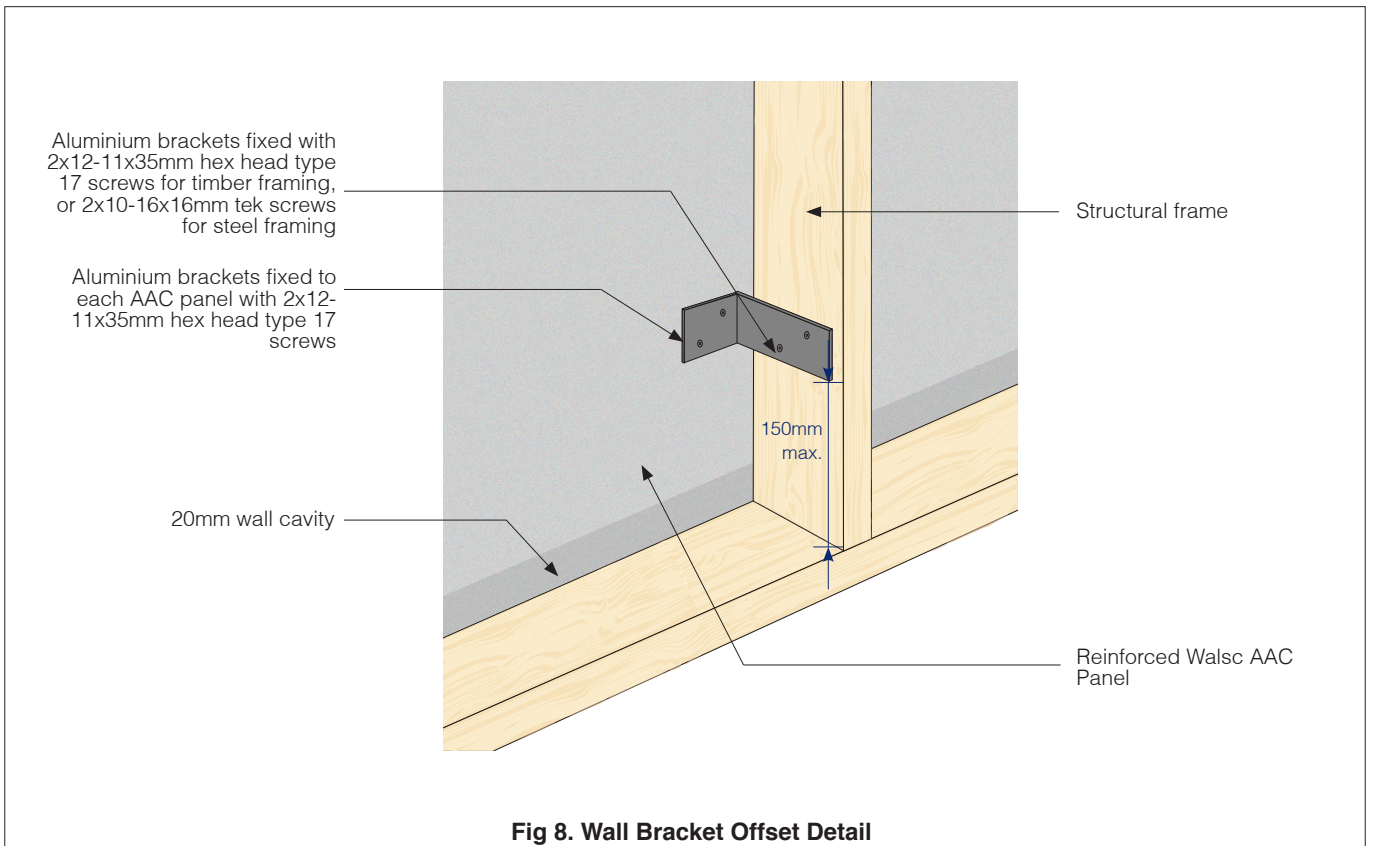
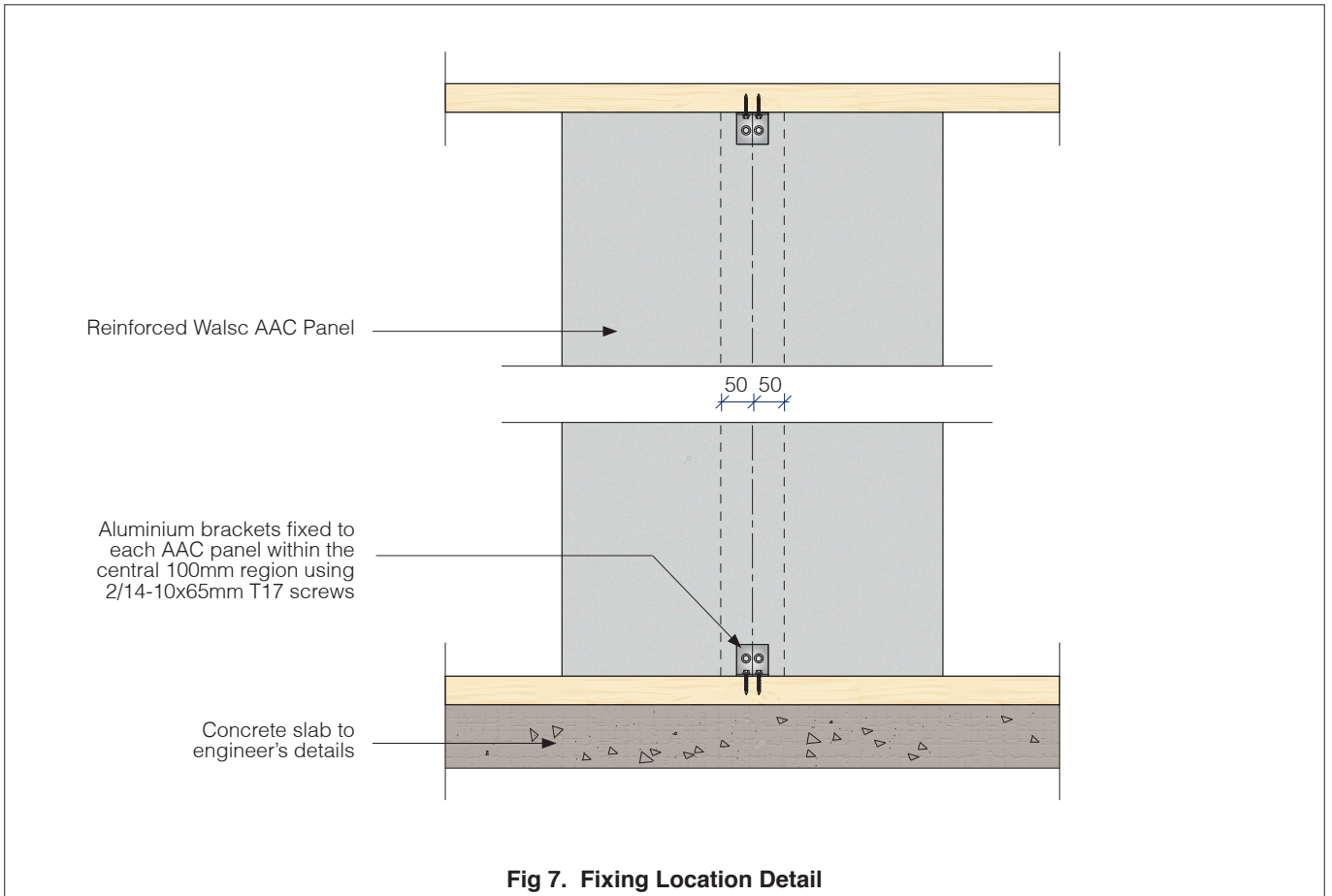
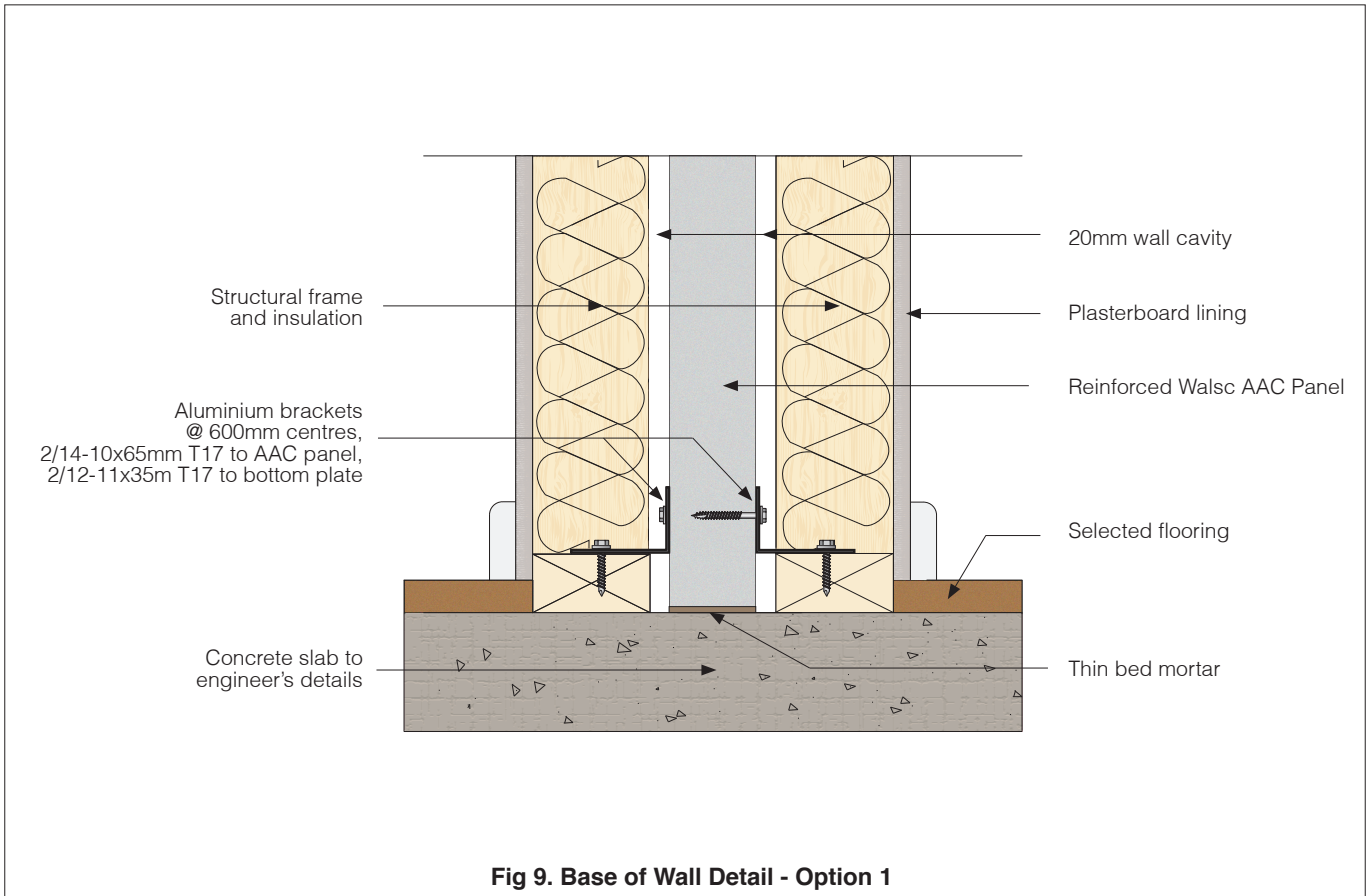


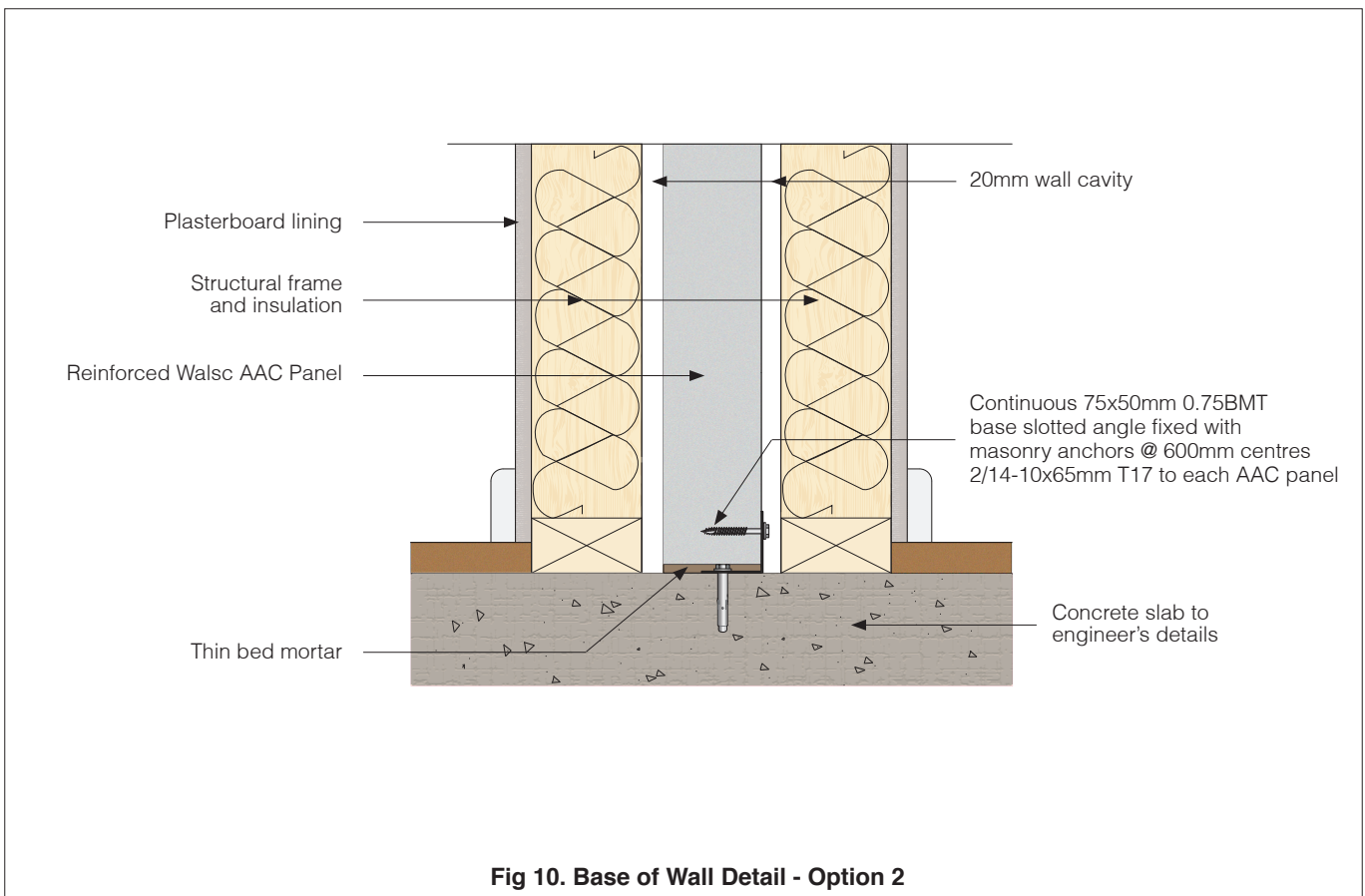
Fig 6. Panel Orientation Elevation Detail





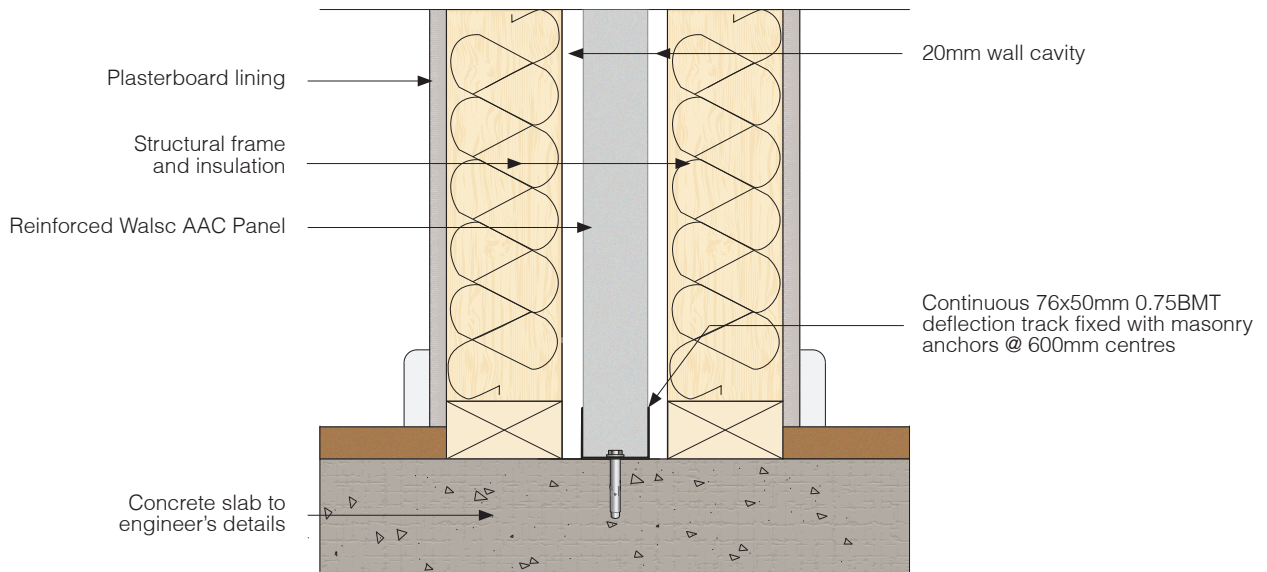


**Fig 9. Base of Wall Detail - Option 1**

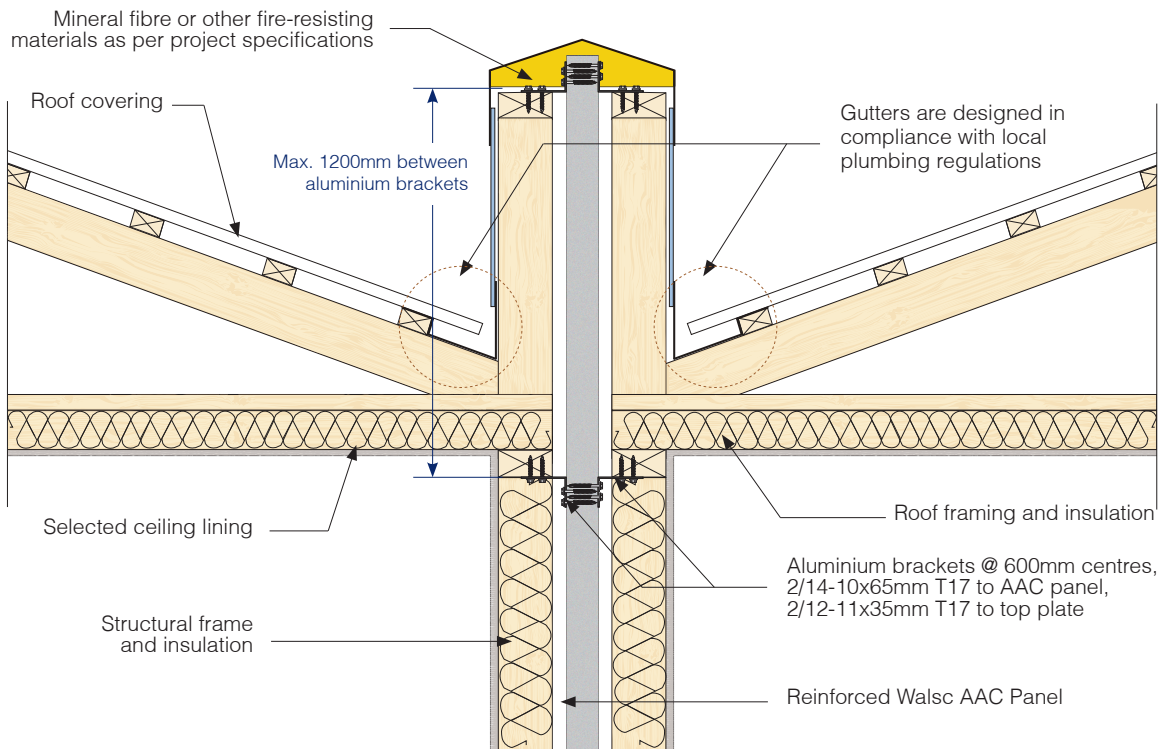


**Fig 10. Base of Wall Detail - Option 2**

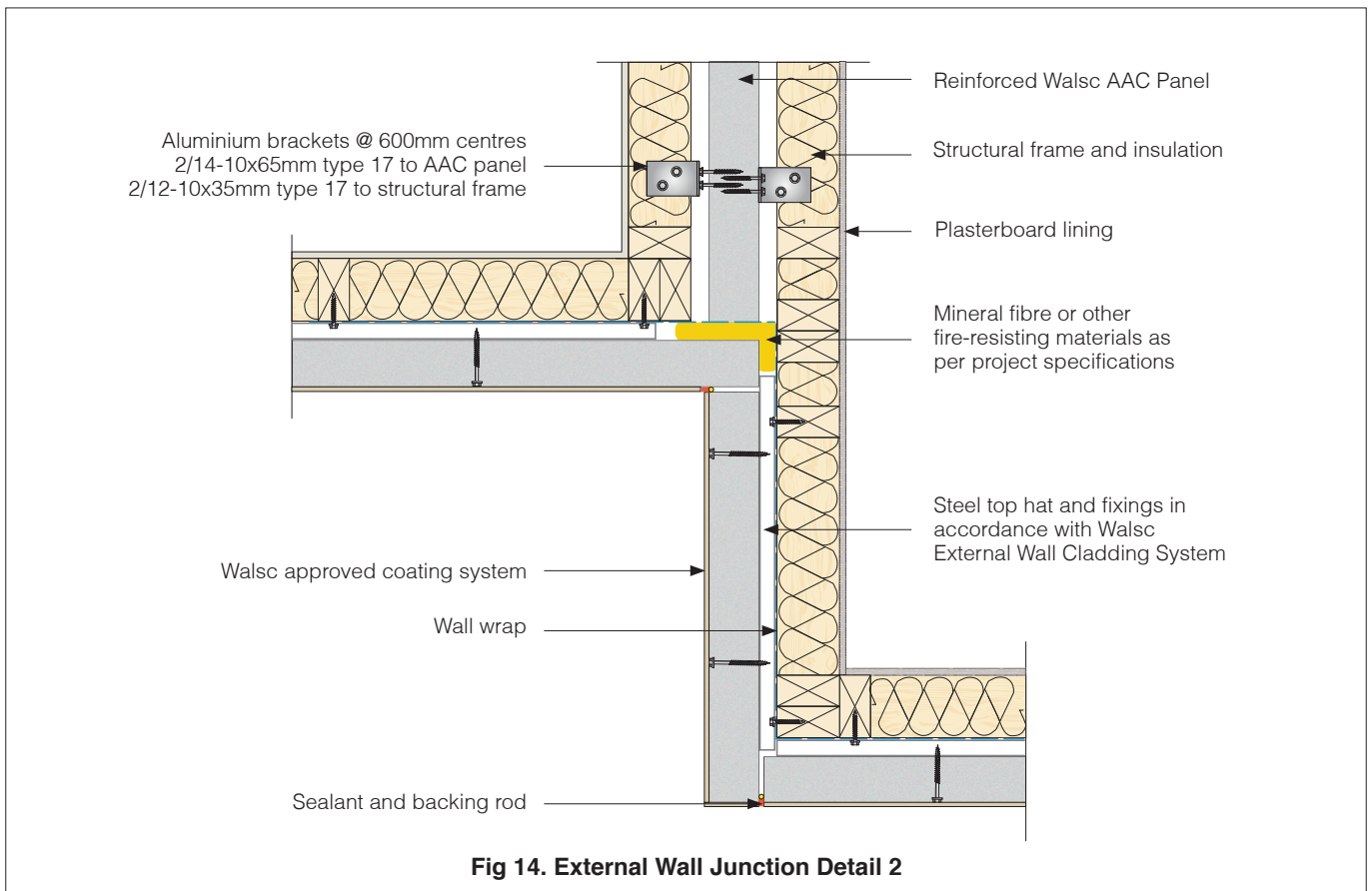
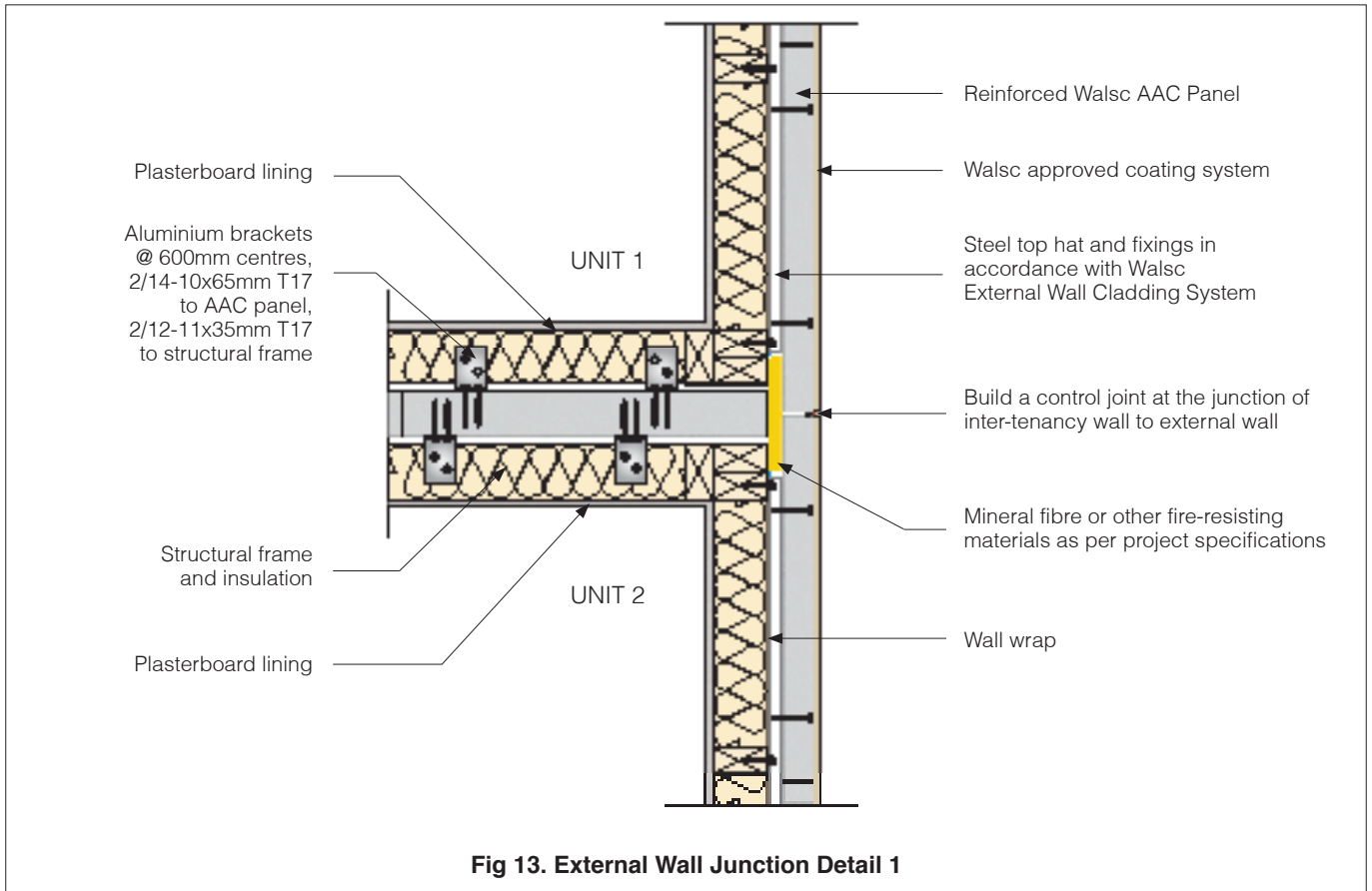


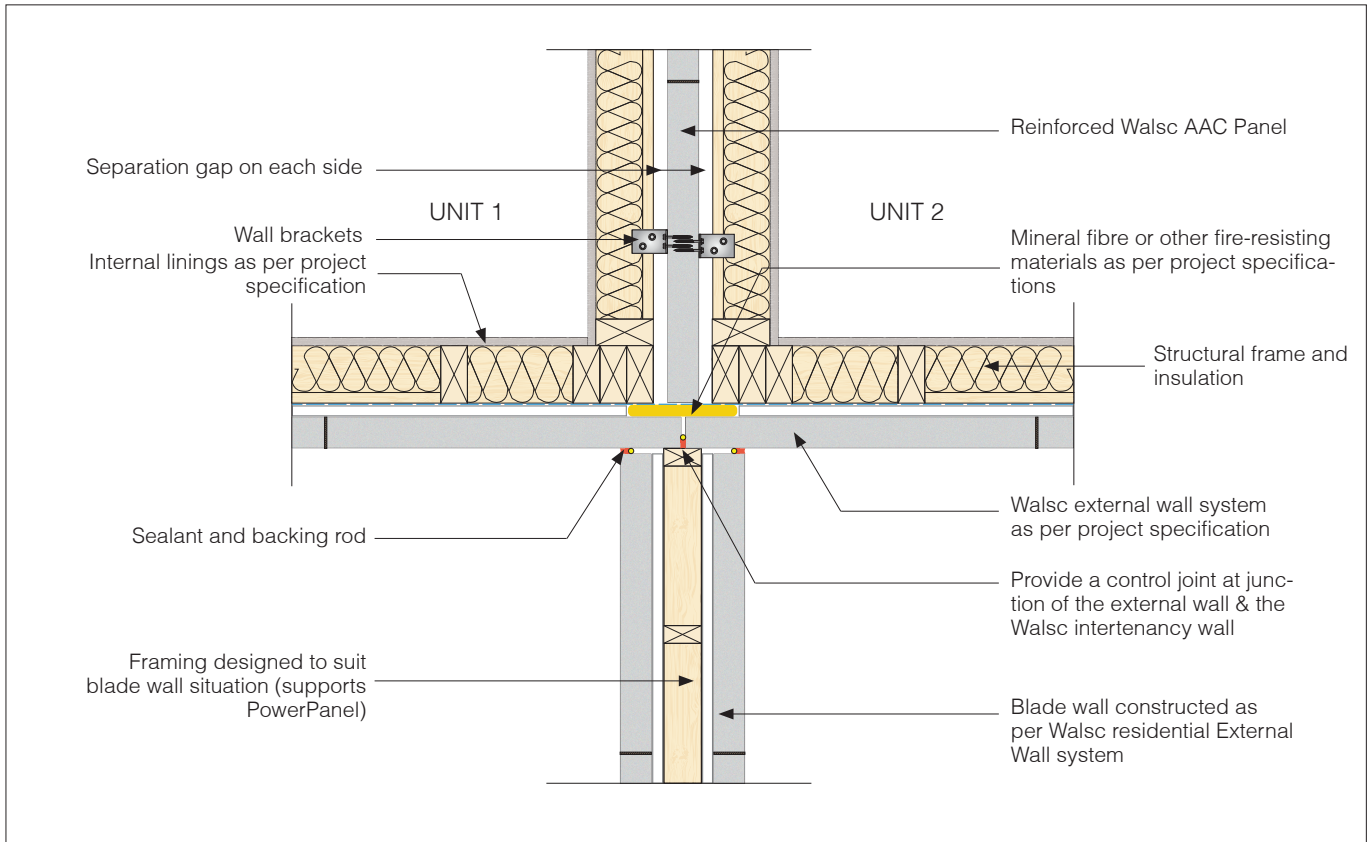


**Fig 11. Base of Wall Detail - Option 3**

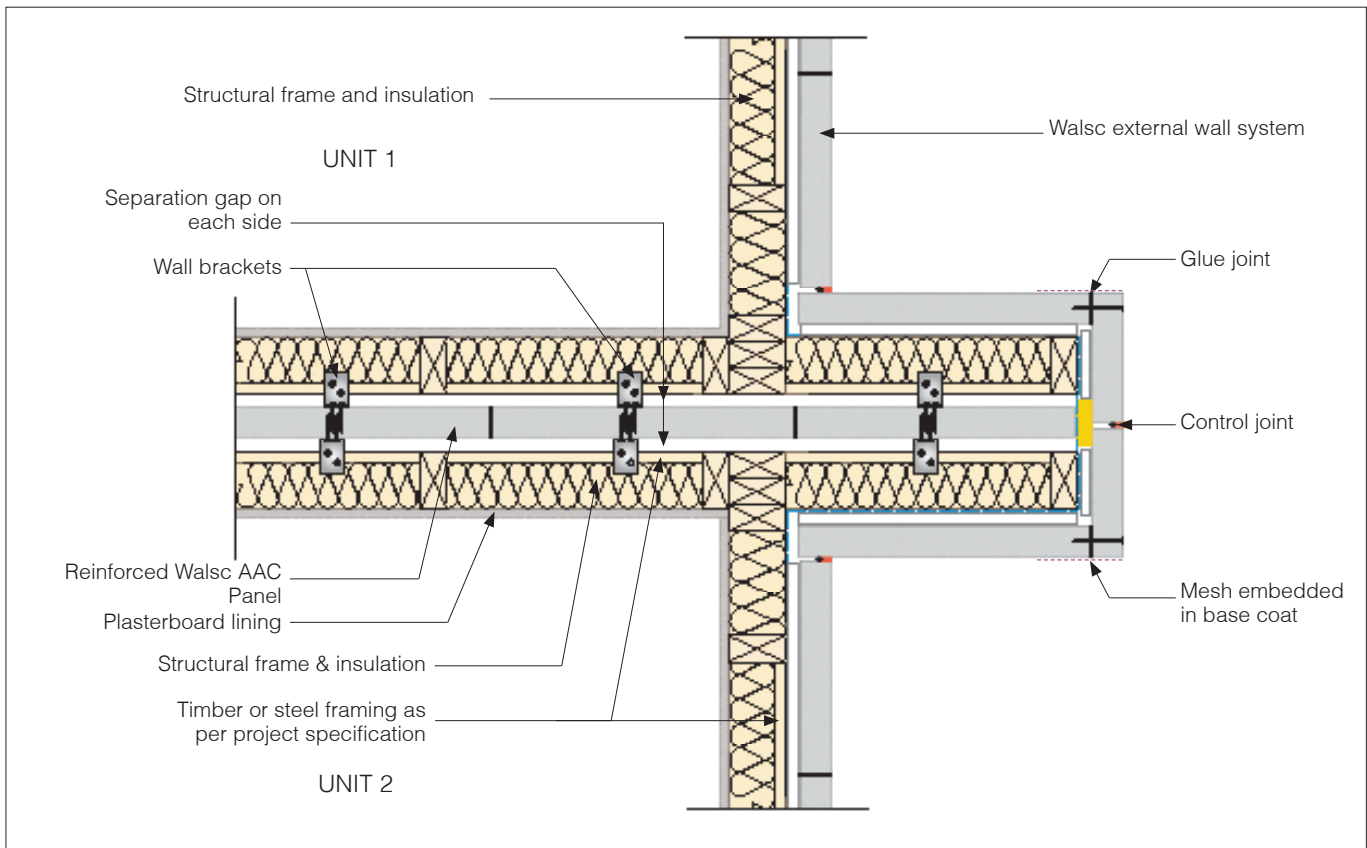


**Fig 12. Roof parapet Detail**

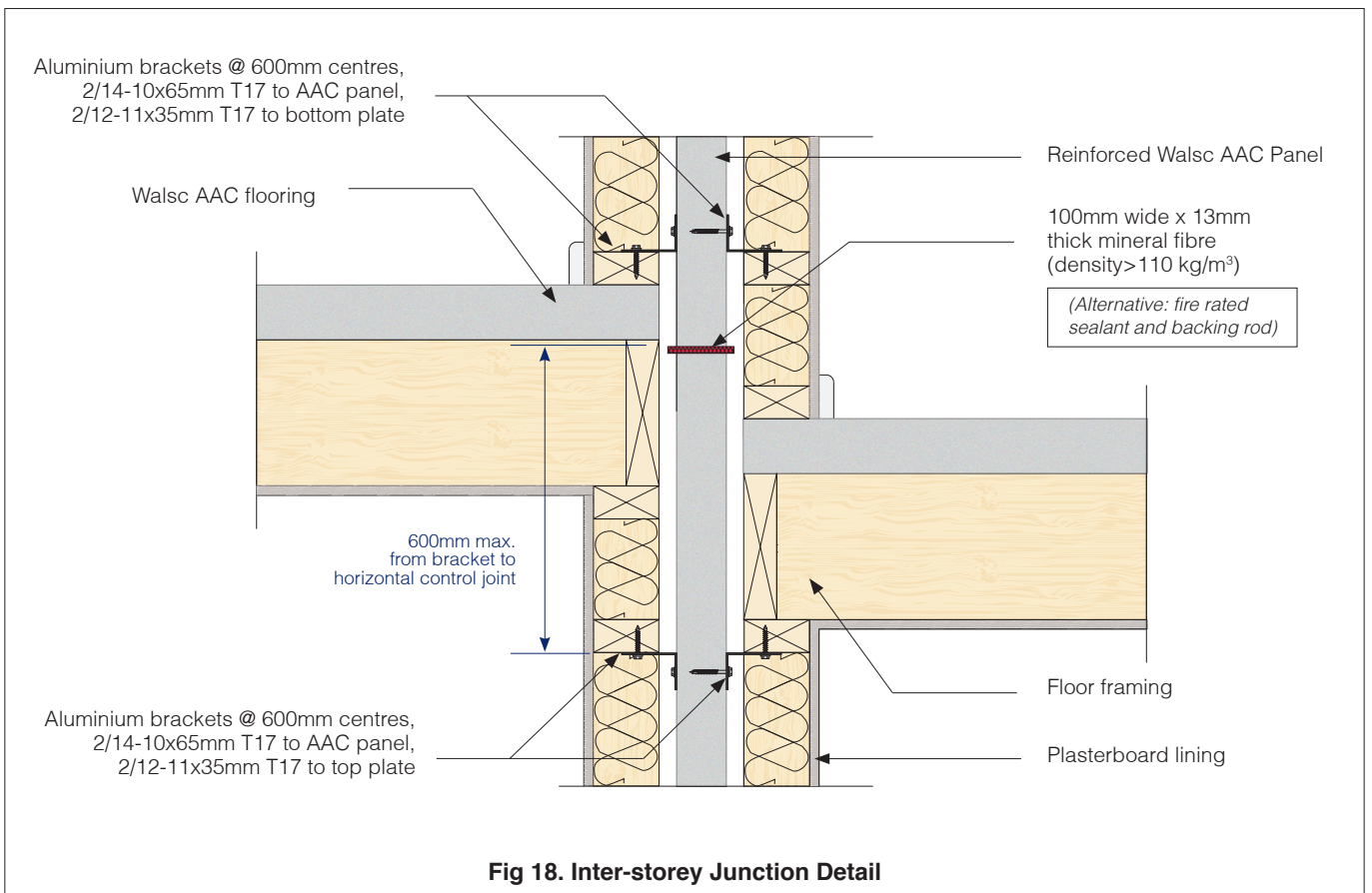
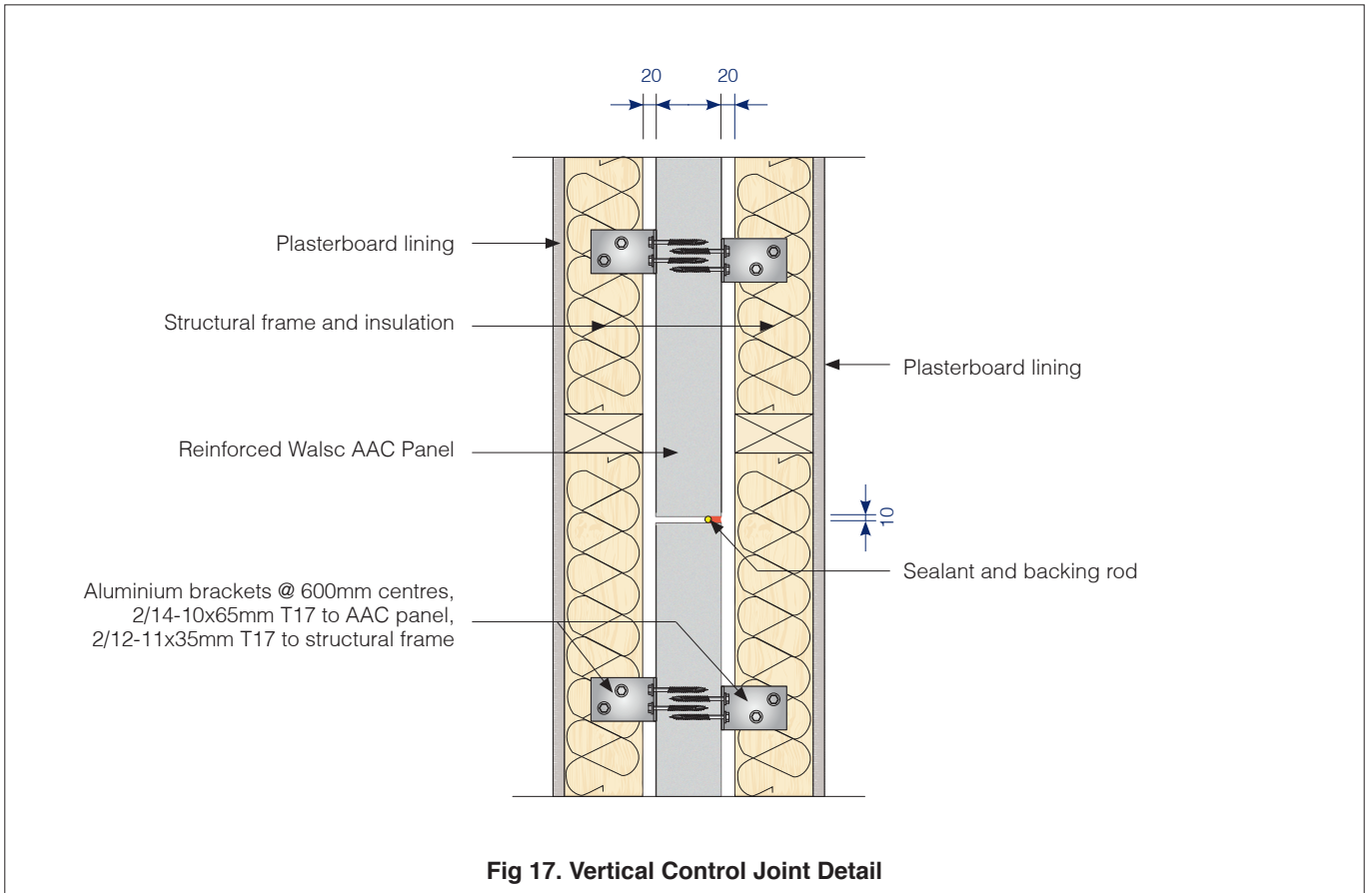




**Fig 15. Blade wall junction detail**



**Fig 16. Nib junction detail of Walsc AAC Panel (50) Intertency wall & External Wall System**



### 11.2 Continuous System

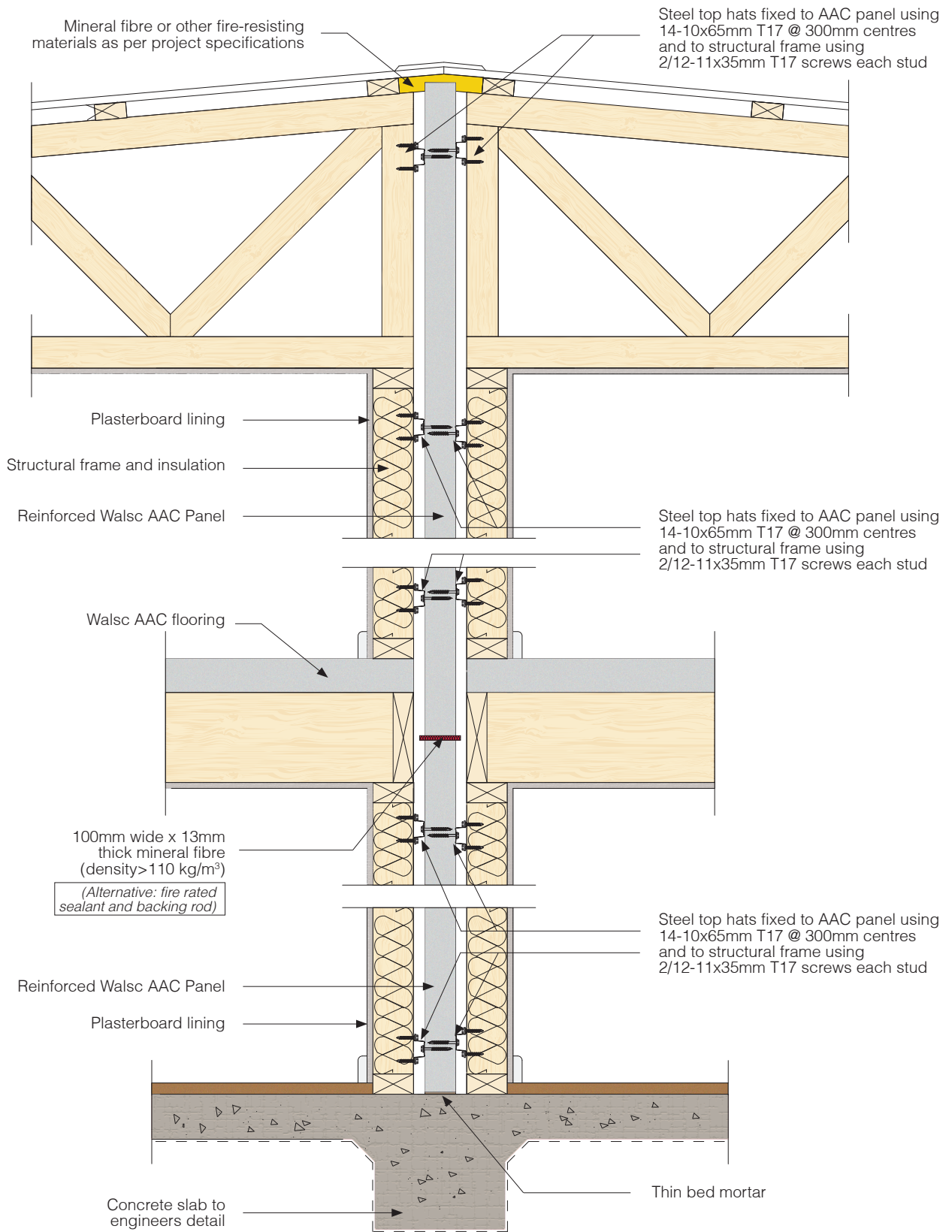
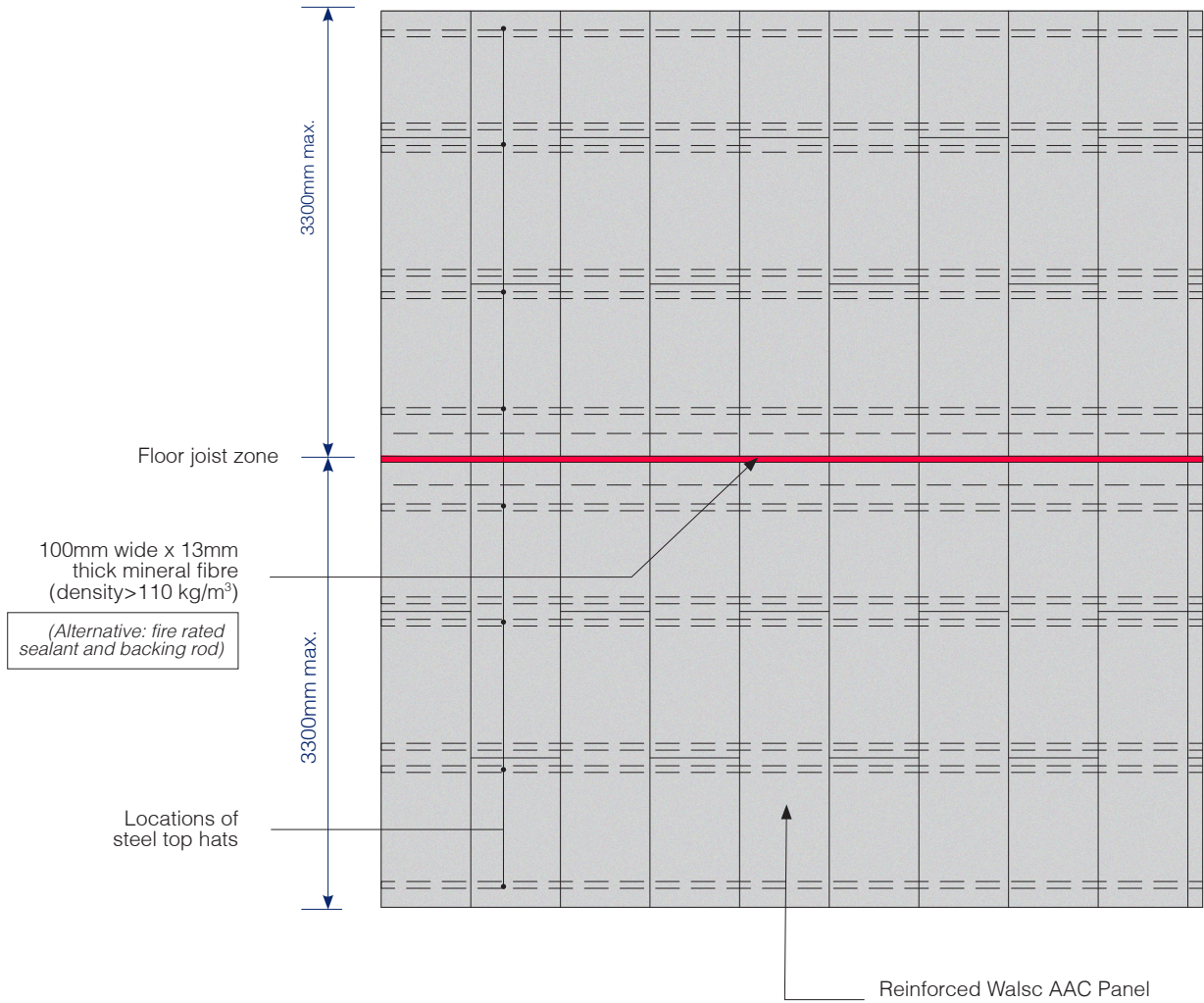


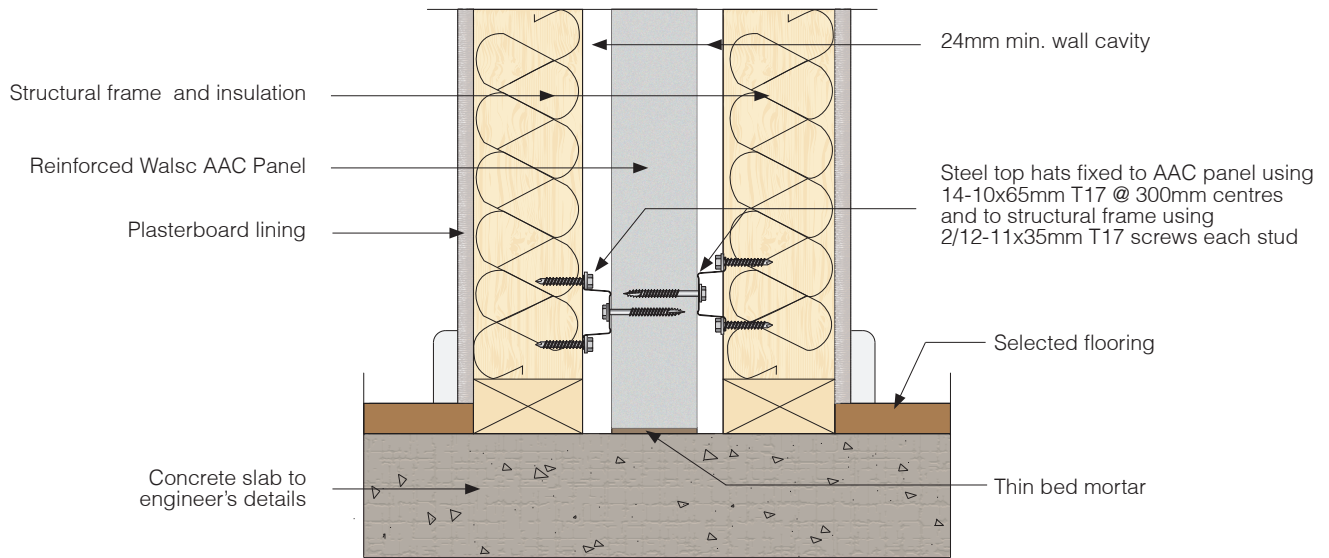
Fig 19. System Cross Section Detail



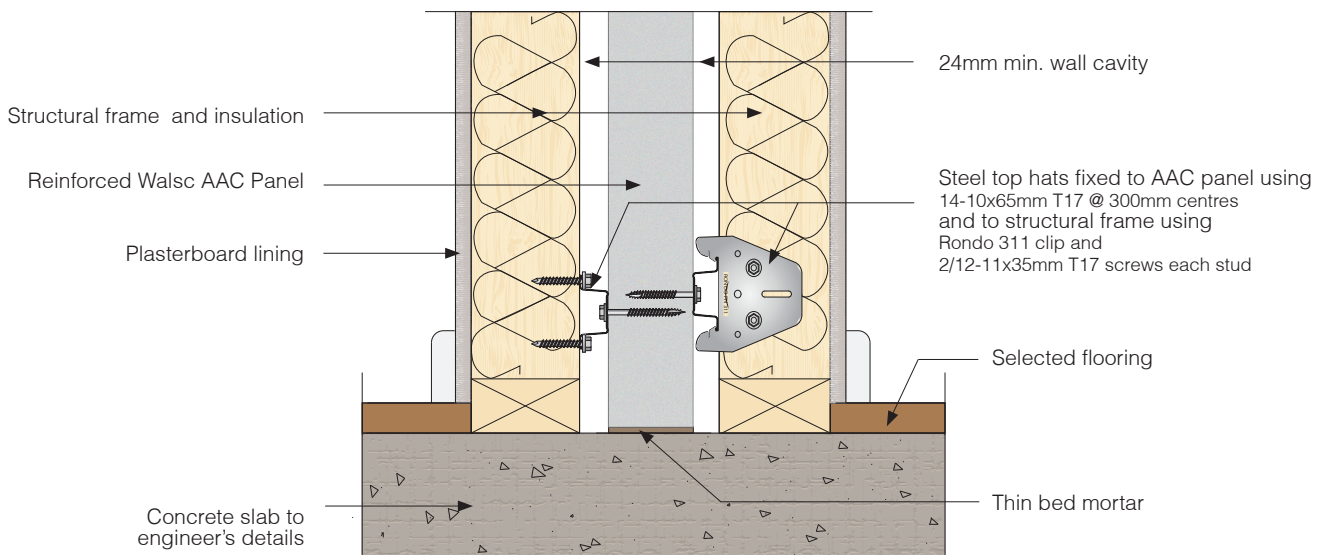


**Fig 20. Panel Orientation Elevation Detail**

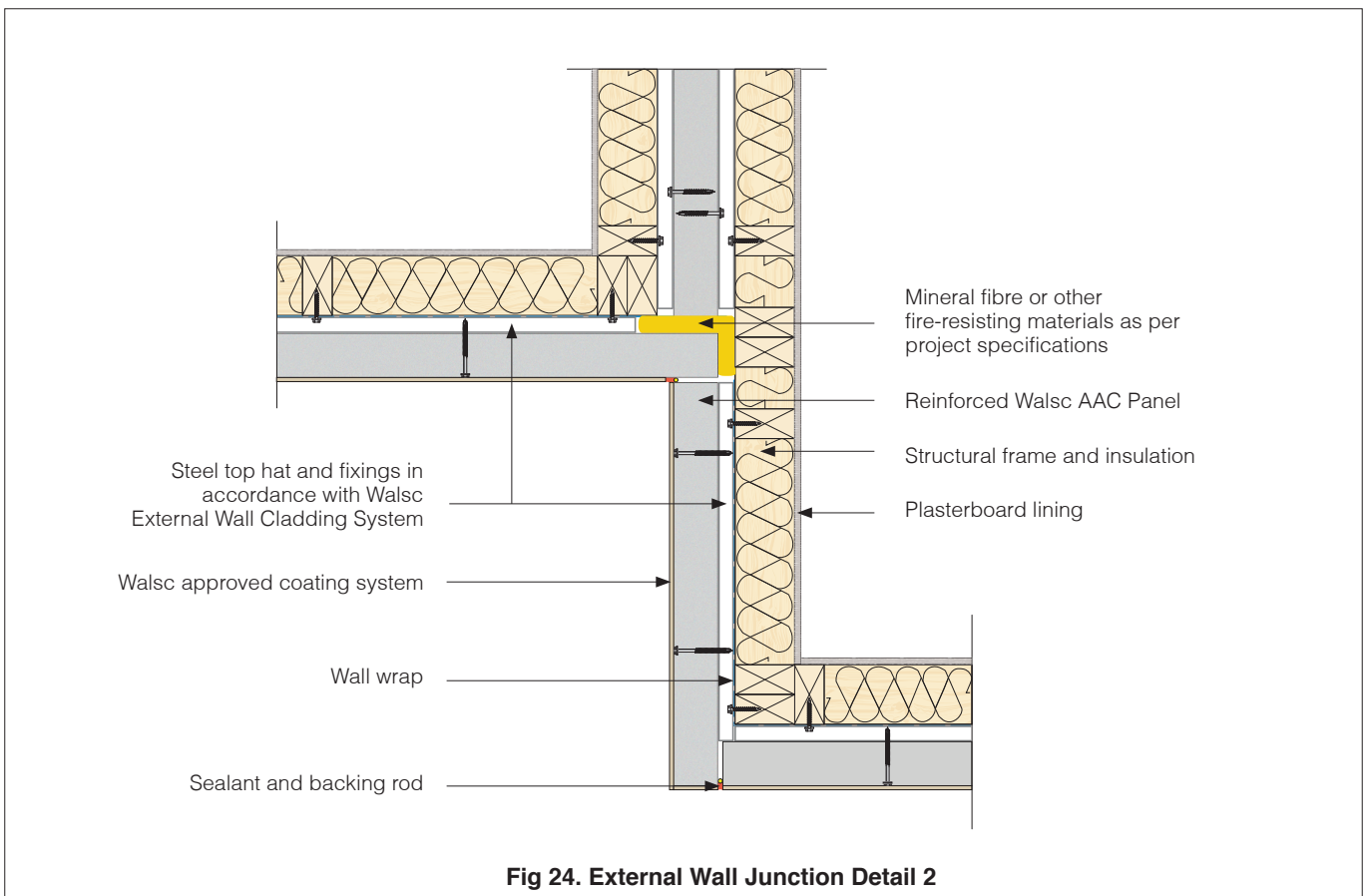
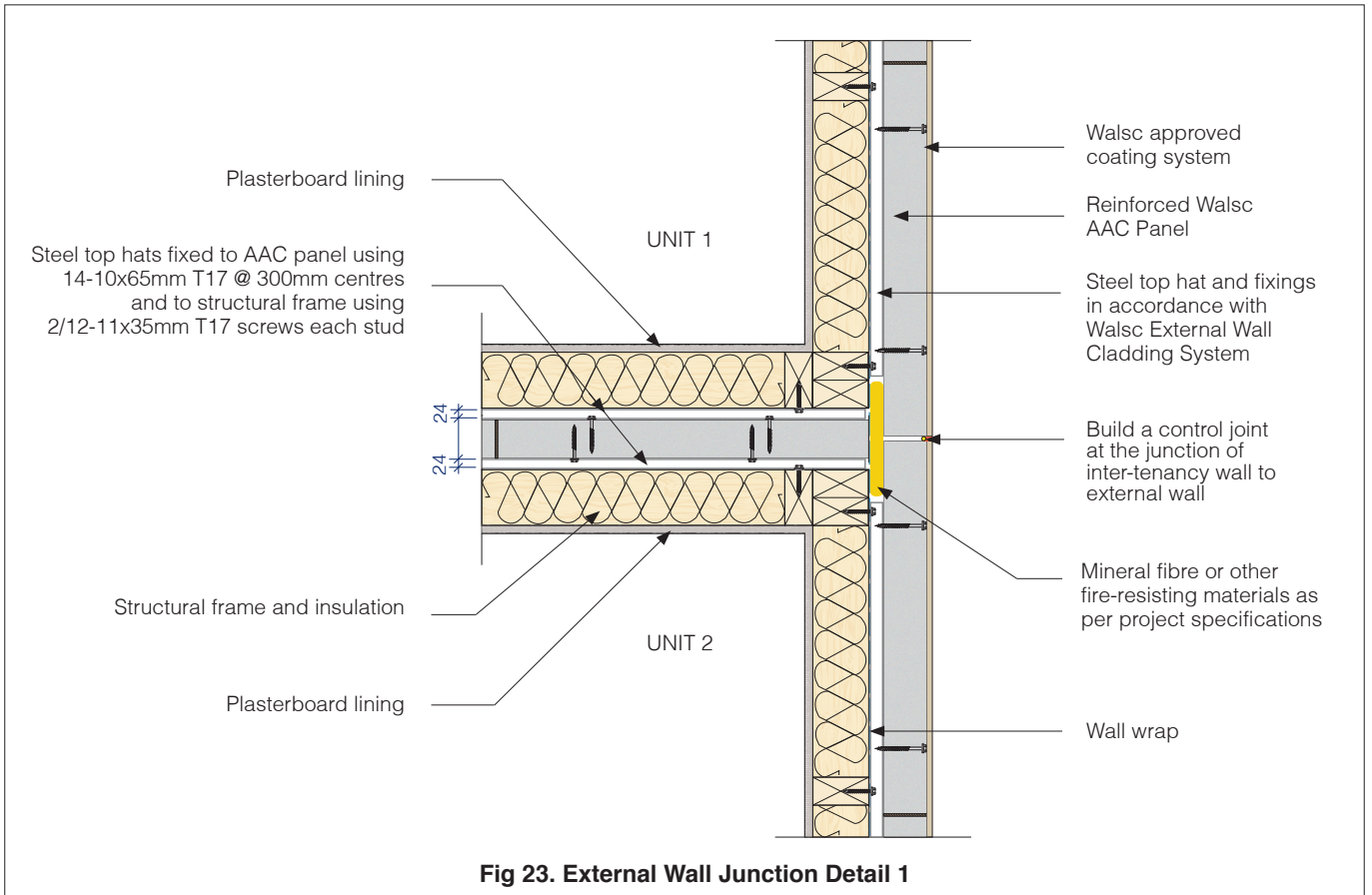


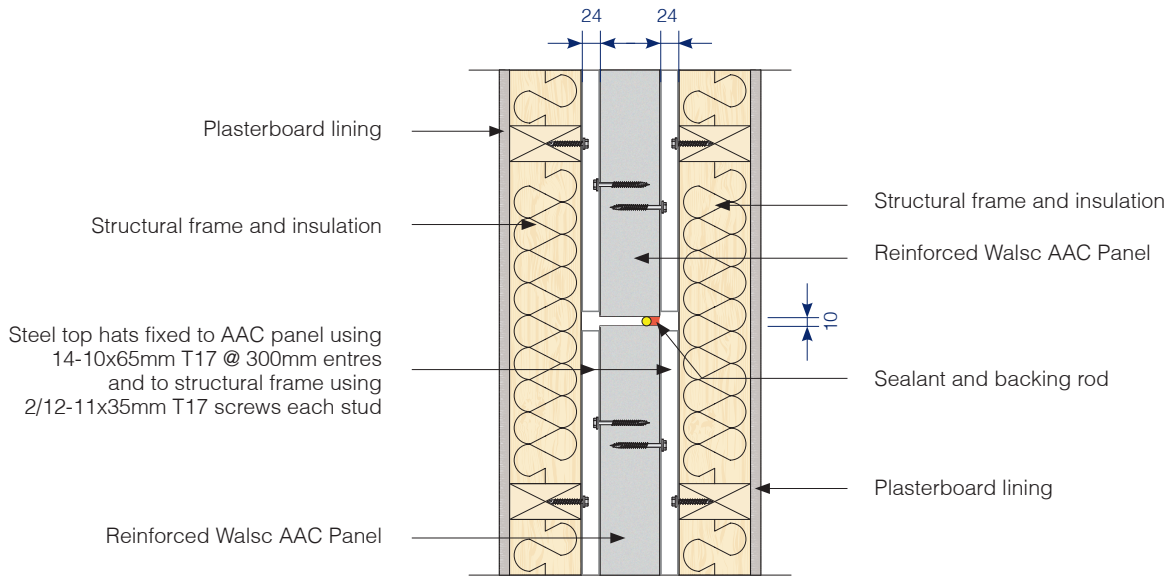


**Fig 21. Panel to Frame Connection Detail - Option 1**

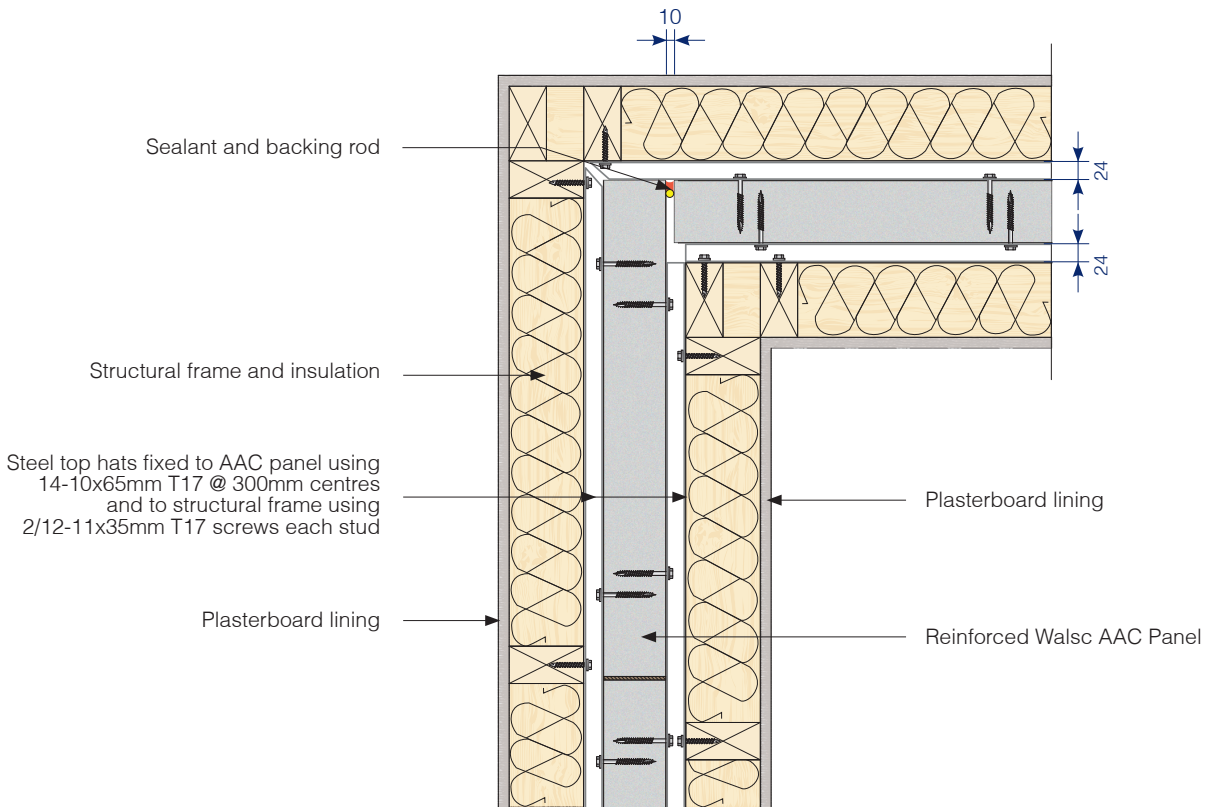


**Fig 22. Panel to Frame Connection Detail - Option 2**










**Fig 25. Vertical Control Joint Detail**



**Fig 26. Corner Vertical Control Joint Detail**



Use Walsc products in low-rise and multi-residential buildings as a better wall or flooring solution.

-  External Wall Cladding System 50
-  External Wall Cladding System 75 Light
-  Inter-tenancy Wall System 50
-  Inter-tenancy Wall System 75 Light
-  AAC Flooring System



**ROCKCOTE**

construction systems

**AVAILABLE FROM**

**Rockcote Pty Ltd**

**Tel: 07 5472 9155**

**Email: [panels@rockcote.com.au](mailto:panels@rockcote.com.au)**

#### Disclaimer

This design guide has been carefully prepared for general guidance only and not intended to be a substitute for the exercise of professional judgment. The information presented in this guide should not be construed as legal, technique, or any other professional advice or service. It is the user's responsibility to confirm the suitability of Walsc products in particular circumstances. Since the application based on the contained information in this document may be beyond our control, neither Walsc nor any of its directors or employees should accept responsibility for loss or damage occasioned to any person acting or refraining from action as a result of inappropriate use of the information. Sipo Building Solutions Pty Ltd reserves the right to alter or update inclusive information from time to time with or without notice.

W202405